

TKT66 TAPSA CONTROL CENTRAL BATTERY UNIT FOR EMERGENCY LIGHTING

Installation and maintenance instructions



 **TEKNOWARE[®]**

Made In Finland

Table of contents

Table of contents	2
1. Safety instructions	4
2. Package contents and storing	4
2.1 Contents of package	4
2.2 Storing	4
3. Product description.....	5
3.1 Manufacturer.....	5
3.2 Terminology.....	5
3.3 Type.....	5
3.4 Explanation of letters (in previous models)	5
3.5 List of optional features.....	6
3.6 General description	6
3.7 Technical specifications.....	7
3.8 Directives and standards	8
4. Description of operations	10
4.1 Purpose of the central battery unit.....	10
4.2 Circuit outputs	10
4.3 Circuit board settings.....	10
4.4 Parallel connection of output circuits	10
4.5 Control unit.....	11
4.5.1 Individual luminaire monitoring test with basic settings.....	11
4.5.2 Circuit monitoring luminaire test with basic settings	11
4.6 Operation of central battery unit	12
4.7 Normal Status	12
4.8 Central module panel	13
4.9 Control Module panel luminaire monitoring LED's and menu settings	15
4.10 Control Module panel test functions and alarms	21
4.12 Buttons.....	23
5. System planning and installation	24
5.1 System planning	24
5.1.1 Luminaire-specific addressable monitoring	24
5.1.2 Circuit monitoring	24
5.2 System installation	24
5.2.1 Parts layout.....	26
5.2.2 Circuit wiring in parallel connection	27
5.2.3 DIP switch settings in circuit boards	28
5.3 Commissioning.....	29
5.3.1 Setting of battery capacity.....	29

5.3.2 Forced charging of batteries	30
5.3.3 Checking the luminaire circuits one at a time	30
5.3.4 Configuration	30
6. Maintenance	31
6.1 Replacing the batteries	31
7. Disposal	32
8. Optional Features	32
8.1 LCD display functions	32
8.1.1 Button functions	32
8.1.2 LCD content	33
8.1.3 LCD menu tree	33
8.1.4 Test history	33
8.1.5 Battery test history	34
8.1.6 Error log	35
8.1.7 Setup	35
8.1.8 External USB connection	36
8.2 Printer	37
8.2.1 Language selection of the printer (TKT66xxC(N)D(L)) or optional feature TST6631	37
8.2.2 Printing out test reports	37
APPENDIX 1: Report Layout	38
APPENDIX 2: Mechanical dimensions	39
APPENDIX 3: Connection alternatives for batteries	41
APPENDIX 4: Circuit diagram with 1-phase input and BCM connection	42
APPENDIX 5: Circuit diagram with 3-phase input	49
APPENDIX 6: Central battery unit main diagram, 1-phase	62
APPENDIX 7: Central battery unit main diagram, 3-phase	63
APPENDIX 8: Menu selections	64

© Copyright 2014 Teknoware Oy – We reserve the right to make modifications without notice

1. Safety instructions

Read before installing the product.

This manual contains important information that must be followed during the installation and maintenance of the central battery unit and the batteries. Installation of this device is allowed only to a person who has the required permissions and qualifications.

National regulations for electric installations and building codes must be observed in the placing of the central battery unit.

In the installation of batteries, constituted regulations must be observed.



WARNING

There is always dangerous voltage level in the output circuits and inside the central battery unit if the central battery unit is switched ON. Changing the main switch to 0 –position will NOT make the central battery unit de-energized. The central battery unit and the battery housing can be opened only by electrically skilled person.

Device must be made de-energized before any maintenance or repair work. Remove the battery fuses and set the main switch to OFF position.

2. Package contents and storing

2.1 Contents of package

The package contains a central battery unit of TKT66XXCxxxx series.

- Store the package sheltered from the rain.
- Do not place anything on top of the package.

NOTE: The package may contain closed lead acid batteries that contain large quantities of energy and may short circuit, if stored inappropriately. This must be considered when storing the package.

2.2 Storing

If you do not install the unit and batteries immediately, note the following:

- Store the unit in a dry place, protected from humidity.
- Store the unit and the batteries in the recommended storing temperature of +10 – 30°C.
- If the batteries are stored for a longer period of time, they must be recharged every 6 months for at least 12 hours at a time.

3. Product description

3.1 Manufacturer

Teknoware Oy
 Ilmarisentie 8
 FI-15200 Lahti
 FINLAND
<http://www.teknoware.fi/>

3.2 Terminology

Term	Explanation
Control	Automatic testing
Maintained	Continuously active
Non-maintained	Active only during voltage interruptions

3.3 Type

Model	Maximum number of circuits	Input Voltage
TKT6608C(N)(P)xx	8	220-240 VAC 50/60Hz 1~
TKT6616C(N)(P)xx	16	220-240 VAC 50/60Hz 1~
TKT6624C(N)(P)xx	24	220-240 VAC 50/60Hz 1~
TKT6608C(N)(P)xxF	8	N/PE 220-240 VAC 50/60Hz 3~
TKT6616C(N)(P)xxF	16	N/PE 220-240 VAC 50/60Hz 3~
TKT6624C(N)(P)xxF	24	N/PE 220-240 VAC 50/60Hz 3~

3.4 Explanation of letters

Letter	Explanation
F	3-phase input
C only	Control function
CD	Control and printer
CL	Control and LCD display
CO	Control and LON interface
CDL	Control, printer, and LCD display
CLO	Control, LCD display and LON interface
N	Charging for NiCd batteries
P	Cabinet construction with a lockable door

3.5 List of optional features

For more information on optional features, see chapter 8. *Optional* .

TST6631	Integrated printer for TKT66xxC
TST6632	LCD display module for TKT66xxC
TST6622	LON Interface for TKT66xxC
TST6601	BACnet Interface for TKT66xxC
TST6621	ACM Interface for TKT66xxC
TST6624	Web server for TKT66xxC
TST1811D	BCM Interface for TKT66xxC
XWT6671	TKT66C switched-maintained package 5-8 MODE links for TK6608C
XWT6672	TKT66C switched-maintained package 13-16 MODE links for TK6616C
XWT6673	TKT66C switched-maintained package 21-24 MODE links for TK6624C
TST6651	Addressable IC package for TKT6608C
TST6652	Addressable IC package for TKT6616C
TST6653	Addressable IC package for TKT6624C

3.6 General description

TKT66xx(N)Cxx central battery unit is designed and manufactured according to the standards EN 50171 and EN 60439-1.

In normal situation, the central battery unit operates using a 230 VAC mains voltage, maintaining the battery charge level and supplying a voltage of 230 VAC to the maintained output circuits. If the mains voltage is interrupted or it drops below 180 V, the central battery unit switches to battery use. This connects a voltage of 220 VDC to the non-maintained circuits and the voltage supply to the maintained circuit switches from 230 VAC to 220 VDC. The battery supply is used as long as the mains voltage remains unavailable or the battery voltage has dropped to the deep discharge limit (173 V).

In addition to the above mentioned standard functions, the control unit of the central battery unit also includes the following monitoring, testing and reporting functions:

- testing the luminaires either through addressable monitoring or by measuring the circuit current and by monitoring the condition of the batteries
- testing the capacity of the battery
- indicating the address of the faulty luminaire with the LED and the number of the circuit, in the addressable monitoring of the luminaires (7 segment display and LED bar)
- indicating the faulty luminaire circuit with the LEDs and the number of the circuit in the circuit monitoring (7 segment display)
- a short operation test time can be set to take place after each 1...7 days
- battery test every 6 months 4.1 and 4.7 at 0.00 o' clock.
- tests can also be started manually
- reporting of the test results on a printer, in the TKT66xxCD(L) models or optional integrated printer TST6631 (= log book)
- LCD display (optional)
- in the report, the test date, possible faulty luminaires, duration of the test and the condition of the battery can be seen
- interface options for central monitoring

The central battery unit does not require any other regular user action after its installation and commissioning than checking the status of the signal LEDs (the left-hand side bar) at specified intervals.

No separate data transfer cables are needed for the luminaires as the data is transferred via the power supply cables.

A self-learning system; luminaires can be added or removed afterwards.

The central battery unit can be set for either addressable monitoring of the luminaires or for circuit monitoring. In the addressable monitoring of the luminaires, the luminaires must be equipped with an address module from Teknoware. All the Teknoware luminaires the type code of which ends in letter **K** are fitted with this feature.

The batteries Pb (18 pcs) or NiCd (180 pcs) for the central battery unit always require a separate battery container and battery cables.

All the functions related to the use of the central battery unit can be performed using its control panel that also includes display LEDs to indicate the status of the unit. The panel functions are described in Chapter 4.6 , Operation of the central battery unit.

3.7 Technical specifications

Mains connection:	220-240 VAC 50-60 Hz 1~, or F-models N/PE 220-240 VAC 50/60 Hz 3~
Casing:	TKT66xxCxx: IP20 TKT66xxCPxx (cabinet construction): IP34
Output voltage:	mains connection: 220-240 VAC, battery operation: 216VDC
Battery voltage:	216 VDC
Battery charging time:	12 h 80 %
Max. batteries:	18 x 65 Ah
Input power TKT6608C(N)(P)xxx:	3680 VA
Max Input power TKT6608CF(P)xxx:	3900 VA
Max Input power TKT6616C(N)(P):xxx	3680 VA
Max Input power TKT6616CF(P)xxx:	6700 VA
Max Input power TKT6624C(N)(P)xxx:	3680VA
Max Input power TKT6624CF(P)xxx:	7100 VA
Ambient temperature range:	+10 – 50°C
Input fuse:	1-phase circuit breaker 16 A C curve or in F-models 3-phase 16 A C-curve
Output circuit fuses:	5x20 mm sand-filled glass tube fuse 2,5 A
Output connector:	max. wire 4 mm ²
Required short-circuit current with 2.5 A fuse 0,4 s. tripping time:	10 A
Battery Fuse TKT6608C(P)xxx:	2x35 A plug fuse S 35 A/250 V Neozed
Battery Fuse TKT6616C(P)xxx:	2x35 A plug fuse S 35 A/250 V Neozed
Battery Fuse TKT6624C(P)xxx:	2x35 A plug fuse S 35 A/250 V Neozed
Charging circuit fuses:	5x20 mm glass tube fuse 6,3 A
Backup battery for CBU settings	Battery type: Teknoware XWT9001 Operation time: min. 12 hrs (with 48 hours of recharge)

Central battery unit type	Output circuits	Total load capacity in battery use with 1-hour and 3-hour operating time
TKT6608C(N)(P)xxx	1x (8x350W/ 4x700W/2x1400W) or 1,6A circuit, Max. 2580VA	1 h 2580 W 18x38 Ah 3 h 2580 W 18x65 Ah
TKT6608C(N)(P)xxxF	1x (8x350W/ 4x700W/2x1400W) or 1,6A circuit, Max.2800VA	1 h 2580 W 18x38 Ah 3 h 2800 W 18x65 Ah
TKT6616C(N)(P)xxx	2x (8x350W/ 4x700W/2x1400W) or 1,6A circuit, Max.2580VA	1 h 5600 W 18x65 Ah 3 h 3340 W 18x65 Ah
TKT6616C(N)(P)xxxF	2x (8x350W/ 4x700W/2x1400W) or 1,6A circuit, Max.5600VA	1 h 5600 W 18x65 Ah 3 h 3340 W 18x65 Ah
TKT6624C(N)(P)xxx	3x (8x350W/ 4x700W/2x1400W) or 1,6A circuit, Max.2580VA	1 h 6000 W 18x65 Ah 3 h 3340 W 18x65 Ah
TKT6624C(N)(P)xxxF	3x (8x350W/ 4x700W/2x1400W) or 1,6A circuit, Max.8400VA	1 h 6000 W 18x65 Ah 3 h 3340 W 18x65 Ah

The central battery unit is equipped with a mains fuse F1 in the connecting terminal and with battery circuit fuses F2 and F3. The output circuits' fuses are on the top end of casing at connectors 1-2.

For more information, see chapter 5.2.1 *Parts layout*

The charging system of the central battery unit is equipped with a temperature compensation of the battery charging voltage, which is approximately 0.06 V/°C (5 mV/°C/cell).

NOTE: The luminaires used with the central battery unit must be suitable for both AC and DC supply.

3.8 Directives and standards

The following directives and standards were applied in designing and manufacturing the central battery unit:

Quality:	ISO 9001: 2008;	(certified quality system)
Environment:	ISO 14001: 2004;	(certified environment system)
Electrical safety:	2006/95/EY	LVD directive
Device standard:	EN 50171: 2001;	Central power supply systems
	EN 50272-2: 2001;	Safety requirements for secondary battery installations Part 2: Stationary batteries
	EN 60439-1 + A1: 2005;	Distribution units. Part 1: Requirements for type tested and partly type tested units.
	IEC 62034: 2006;	Automatic test systems for battery powered emergency escape lighting

Electromagnetic compatibility:	2004/108/EC	EMC directive
	EN 61000-6-3: 2001;	Electromagnetic compatibility (EMC)-Part 6-3: Generic standard - Emission standard for residential, commercial and light industrial environments.
	EN 61000-6-2: 2005;	Electromagnetic compatibility (EMC) - Part 6-2: Generic standards - Immunity for industrial environments

4. Description of operations

4.1 Purpose of the central battery unit

In a normal situation the purpose of the central battery unit is to

- monitor the mains voltage
- maintain the battery charge level
- supply power for the maintained emergency luminaires

During a mains failure the central battery unit will supply voltage to the maintained and the non-maintained emergency lighting circuits from the batteries.

The central battery unit also includes functions for testing and monitoring the condition of the luminaires and the batteries.

4.2 Circuit outputs

Circuit output connections can be selected as maintained or non-maintained mode from circuit board. For more information, see chapter *5.2 System installation*.

4.3 Circuit board settings

In the central battery unit there are 1-3 circuit boards. Every board has eight output circuits. On circuit boards there is a DIP-switch selector that defines the characteristic of the board. The functions of the DIP-switches are:

- DIPs 1-3 give the board its internal address
- DIP 4 defines whether the board uses addressable central monitoring or circuit monitoring. Set to OFF position defines board to use addressable central monitoring.
- DIPs 5 and 6 are used when the parallel connection of the output circuits is used.

For information on the circuit boards' DIP settings details, see chapter *5.2.3 DIP switch settings in circuit boards*.

4.4 Parallel connection of output circuits

Output circuits can be connected parallel to get a bigger circuit output power.

- Factory settings give 8x 350 W output power
- Two circuits connected parallel gives 4x 700 W output power
- Four circuits connected parallel gives 2x 1400 W output power

For more information on making a parallel connection between output circuits, see chapter *5.2.2 Circuit wiring in parallel connection*.

NOTE: When parallel connections are used, the output circuits' connectors running the circuit numbers may change. The circuit numbers must be changed to correspond with the amount of the connected circuits.

4.5 Control unit

The monitoring function of the central battery unit can operate using three different operating principles: addressable monitoring, circuit monitoring or a combination of both. This is selected with the DIP switch 4 (see more information in Chapter 5.2.3 *DIP switch settings in circuit boards*). Addressable monitoring and circuit monitoring can be set for different circuit boards within the same unit: 8 circuits on addressable monitoring, 8 circuits on circuit monitoring, etc.

In addressable monitoring of the luminaires, each luminaire has its own unique address. There can be 1...32 luminaires in one circuit. The luminaires have LOW 1-16 (luminaires 1-16) and HIGH 1-16 (luminaires 17-32) addresses. For example, the luminaire HIGH 2 indicates luminaire number 18. On the display of the central battery unit this is presented with the letters **L** (LOW) or **H** (HIGH). The central battery unit checks the operation and indicates the result for each luminaire separately.

The circuit monitoring measures the current of a circuit in battery mode. The changes in the current are used to determine possible faults in the circuit. The number of luminaires in a circuit is not limited, but the input power of a circuit cannot exceed 350 VA or 1,6 A. Note that circuit monitoring doesn't give luminaire-specific information. The limit value of the error alarm can be changed in the settings, (1-31) = +/- 10.. 310 mA. The factory settings are 16 = +/- 160 mA.

NOTE: In parallel connection, the current values are multiplied by the number of the parallel connected circuits. 700 W = 2x or 1400 W = 4x.

NOTE: If circuit monitoring current limits are changed in a configured centre, the unit goes into a non-configured state and must be re-configured.

The descriptions of the signal LEDs and the buttons are presented in chapters 4.9 *Control Module panel luminaire monitoring LED's and menu settings* and 4.11 *Buttons*.

4.5.1 Individual luminaire monitoring test with basic settings

As a basic setting, the luminaire test is done automatically once a day at a predetermined time. The central battery unit carries out the test as follows:

The central battery unit switches to battery mode and the *Battery Oper.* and the *Luminaire Test* LEDs are lit for the duration of the test. L or H and the circuit number is displayed on the display of the control unit. Whenever a functioning luminaire is detected, an indicator light is lit. After all circuits are tested, the system returns to normal mode.

If a malfunctioning luminaire is found from any circuit, an indicator light will blink on the display. Also, the *External fault* LED is lit and the external error alarm relay will operate. In correctly functioning luminaires the LEDs are lit evenly.

For more information about testing the luminaires, see Chapter 4.10 *Control Module panel test functions and alarms*.

4.5.2 Circuit monitoring luminaire test with basic settings

As a basic setting, the luminaire test is done automatically once a day at a predetermined time. The central battery unit carries out the test as follows:

The central battery unit switches to battery mode and the *Luminaire test* LED is lit for the duration of the test. The current of each circuit is measured and the circuit number increases as the test progresses. The LEDs representing the measured relative current of each circuit will be lit. After all circuits have been tested, the software returns to normal mode.

A fault indication will be given if in any of the circuits the measured current differs more than +/- 80 mA when compared to the value which was stored during the last configuring. Each one LED in the column represents a +/- 100 mA of current in a circuit. The deviation against the configured value is shown by flashing the LEDs corresponding the difference. The more LEDs there are flashing, the bigger is the difference and more luminaires are likely to be failed. With the settings the current range can be changed between 10 and 310 mA. The displays of the LEDs also operate in within this range. Also, in

this case the *External fault* LED will be lit and the external error alarm relay will operate. In working luminaire circuits, the LEDs are lit evenly.

More information about testing the luminaires, see Chapter 4.10 *Control Module panel test functions and alarms*.

NOTE: In parallel connection the current values are multiplied by the number of the parallel connected circuits. 700 W = 2x or 1400 W = 4x.

4.6 Operation of the central battery unit

The functions are accessed by the menu structure. The green LEDs on the LED column show the basic menu option and the number display shows the sub-options or values of it.

The menu functions of LEDs 1 and 2 are so-called basic functions. All other functions are related to the settings of the central battery unit. The latter do not need to be changed in normal use. When the menu functions are used, the central battery unit returns to normal mode if no functions are used for two minutes. All functions can also be done via Bus interface using centralised management software.

4.7 Normal Status

In normal status the number display rotates the information of all circuits connected to the central battery unit. In addressable monitoring the display will show the number of the circuit and the LED corresponding to a luminaire will be lit. In circuit monitoring, the LEDs numbered from 16 to 1 will be lit; the bigger the circuit input power, the greater the number of lit LEDs.

The information of each circuit will be shown for about four seconds at a time.

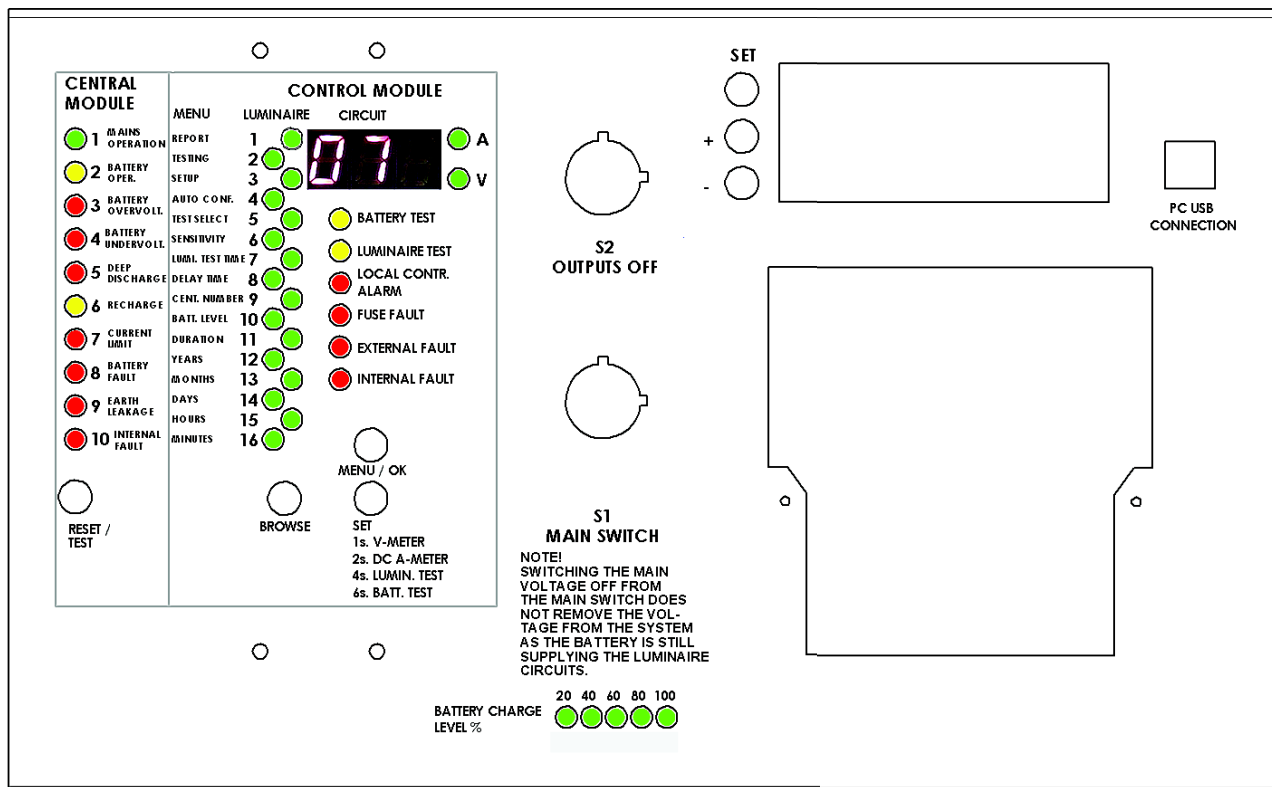

4.8 Central module panel

LED	Description	Reason for problem and solution
1 MAINS OPERATION	<p>The central battery unit is using mains current.</p> <p>The central battery unit can be switched into emergency mode also remotely, if the remote control feature has been activated. In this case: <i>Mains operation</i> is flashing <i>Battery operation</i> is lit</p>	<p>If <i>Mains operation</i> led is not lit, main fuse can be blown or mains voltage is not present.</p>
2 BATTERY OPER.	<p>The central battery unit is using battery power. This means that the mains voltage is interrupted or it has dropped below 180 V.</p> <p>The central battery unit can be in battery operation because external control has switched it to emergency mode.</p> <p>The central battery unit is in luminaire or battery test.</p>	<p>Indicates if power is coming from battery.</p> <p>Once the mains voltage recovers or increases above 195 V, the central battery unit switches back to mains voltage use and begins to charge the batteries.</p> <p>The battery is automatically recharged after the mains voltage recovers.</p>
3 BATTERY OVERVOLT.	<p>The battery voltage has increased above 255 V (N = 278 V) in a normal situation.</p> <p><i>Battery fault</i> and <i>Internal fault</i> LEDs are also lit.</p>	<p>Battery charger is charging batteries with too high voltage. Charger is faulty and it must be changed.</p> <p>and/or</p> <p>Batteries are at the end of their lifetime and must be changed.</p>
4 BATTERY UNDERVOLT.	<p>The battery voltage has dropped below 228 V (N = 244 V) in a normal situation.</p> <p><i>Battery fault</i> and <i>Internal fault</i> LEDs are also lit.</p>	<p>The central battery unit has been long time in battery operation.</p> <p>Battery charger or batteries can be faulty and must be changed.</p> <p>Check battery condition. Every cell must have about the same voltage level. Otherwise some battery cell is in short circuit.</p> <p>Check that temperature sensor is connected properly and it is working. Resistance should be about 2 kOhm. Voltage over sensor should be about 5 Vdc.</p>
5 DEEP DISCHARGE	<p>When this LED flashes, the battery voltage has dropped below 195 V (N = 210 V). (an early warning for a deep discharge). <i>Internal fault</i> LEDs are also lit.</p> <p>When this LED is lit, the battery voltage has dropped to the deep discharge limit (173 V). <i>Battery operation</i> and <i>Internal fault</i> LEDs are also lit.</p>	<p>Check that remote control link is closed (CON5 pins 62 and 63).</p> <p>Check that mains voltage is coming to Central Battery Unit.</p> <p>The <i>Deep discharge</i> LED stays lit until it is reset with the Reset / Test button.</p> <p>The mains voltage must have returned before the deep discharge alarm can be reset.</p>

		<p>If battery voltage is below deep discharge limit, push forced charge button from charger, see instructions in chapter 5.3.2.</p> <p>Check that temperature sensor is connected properly and it is working. Resistance should be about 2 kOhm. Voltage over sensor should be about 5 Vdc.</p>
6 RECHARGE	<p>When this LED is flashing, the battery is recharging but the voltage has not yet reached the maintenance voltage.</p> <p>When this LED is lit, the battery voltage has reached the maintenance voltage.</p> <p>After a power failure the batteries are first boost charged using a constant current. The boost charging and the cyclic charging normally take 12 hours, after which the device switches to trickle charging, i.e. the normal mode. In a normal mode, the battery voltage is kept in about 243 V (N = 261 V). The charging current can be selected from the charging board by using a DIP switch.</p>	
7 CURRENT LIMIT	Not in use	
8 BATTERY FAULT	<p>Possible fault in the battery or its cabling.</p> <p>This LED can be lit with other LEDs that indicate the fault more specifically.</p> <p>If the battery is disconnected, the charger doesn't charge, the battery fuse is blown or the battery doesn't accept charging current, the following alarms are displayed on the panel:</p> <ul style="list-style-type: none"> • <i>Mains operation</i> LED • <i>Battery undervoltage or overvoltage</i> LED • <i>Battery fault</i> LED • <i>Internal fault</i> LEDs 	<p>Battery fuses might be blown.</p> <p>Refer to the instructions given for the LED that specifies the battery fault (Battery overvoltage, Battery undervoltage and Deep discharge).</p> <p>To reset the possible battery fault alarm, press the Reset / Test button.</p>
9 EARTH LEAKAGE	Possible earth leakage inside the central battery unit.	<p>Earth leakage detection will check if positive pole of the battery has leakage to the body of the central battery unit.</p> <p>If there is not earth leakage, the earth leakage sensor might be broken.</p>

<p>10 INTERNAL FAULT</p>	<p>This LED alarms when some internal fault of the central battery unit is detected, a fault in the battery or the charging circuit.</p> <p>This LED can be lit with other LEDs that indicate the fault more specifically.</p> <p>This LED is also lit when the batteries are being changed.</p>	<p>Refer to the instructions given for the LED that specifies the battery fault.</p>
---------------------------------	--------------------------------------------------------------------------------------------------------------------------------------------------------------------------------------------------------------------------------------------------------------------------------------------------	--------------------------------------------------------------------------------------

4.9 Control Module panel luminaire monitoring LED's and menu settings

LED	Description	Instruction
<p>Number display</p>	<p>Shows the number of the circuit whose luminaires are shown with LEDs 1-16.</p> <p>If "CC" is flashing on the display, the system has not been configured.</p>	<p>For configuring the system, see chapter 5.3.4 <i>Configuration</i>.</p>
<p>LEDs 1-16</p>	<p>There are two meanings of these leds:</p> <ol style="list-style-type: none"> To show information of the luminaires. <ul style="list-style-type: none"> How many luminaires installed and address of the luminaires. Status of the luminaires. To indicate selection in menu <ul style="list-style-type: none"> Instructions how to check and change settings from menu are below. 	<p>Addressable monitoring: The LEDs display the status of luminaires in the aforementioned circuit.</p> <ul style="list-style-type: none"> If the LED is continuously lit, the luminaire is functional. If the LED is flashing, the luminaire is faulty. If the LED is not lit, no luminaire has been assigned for that address. <p>Circuit monitoring: The LED bars display the total input power of the circuit. If the LED or LEDs are flashing during circuit monitoring, an error has been detected in the circuit.</p> <p>See the instructions given for corresponding LEDs.</p>
<p>1 REPORT</p>	<p>Use this option to print out report of the configuration of the central battery unit and the status of the luminaires.</p> <p>Value 1 = Print a report of all circuit.</p> <p>NOTE: This action requires a printer, which is an optional feature TST6631 or the central battery units of the type Tapsa Control TKT66xxC(N)D(L).</p>	<p>To print a report,</p> <ol style="list-style-type: none"> Go to the menu with the MENU / OK button. <p>The REPORT LED is lit.</p> <ol style="list-style-type: none"> Press the SET button once. <p>Number 1 will appear in the display.</p>

		<p>3. Acknowledge by pressing the MENU / OK button again.</p> <p>Printing of the report will start.</p> <p>NOTE: Printing of the reports is blocked during the tests.</p>
<p>2 TESTING</p>	<p>Use this option to select a test to be started or interrupted.</p> <p>1 = Start of the luminaire test.</p> <p>2 = Interruption of the luminaire test.</p> <p>3 = Start of battery test for 2/3 of the time (the same time as in the automatic test).</p> <p>4 = Start of the battery test for the set operating time (1 or 3 hours).</p> <p>5 = Start of the battery test until the end of its duration – the battery will be discharged.</p> <p>6 = Interruption of the battery test / acknowledging of a battery fault.</p> <p>7 = Stop the local controller function or the BLINK mode.</p> <p>8 = Start the local controller function.</p> <p>9 = Start the BLINK mode.</p> <p>10 = Reconfiguration.</p>	<p>To start or interrupt a test,</p> <ol style="list-style-type: none"> 1. Go to the menu with the MENU / OK button. 2. Press the BROWSE button until the TESTING led is lit. 3. Press the SET button until the value you wish to select shows in the display. <p>For example 6 = Interrupt the battery test.</p> <ol style="list-style-type: none"> 4. Acknowledge by pressing the MENU / OK button again. <p>The required action begins.</p>
<p>3 SETUP</p>	<p>Use this option to remove the settings locking to change the operational settings of the central battery unit.</p>	<p>To remove the settings locking,</p> <ol style="list-style-type: none"> 1. Go to the menu with the MENU / OK button. 2. Press the BROWSE button until the SETUP led is lit. 3. Press the SET button so that number “1” shows in the display. 4. Acknowledge by pressing the BROWSE button again. <p>The settings locking is removed and you can now change the operational settings.</p>

<p>4 AUTO CONF.</p>	<p>Use this option to change the status of the automatic configuration.</p> <p>The default setting is 0, meaning that the automatic configuration is OFF.</p> <p>NOTE: This function only works in addressable monitoring. If circuit monitoring is chosen, the central battery unit needs to be reconfigured after changing the circuit load.</p>	<p>To change the automatic configuration status,</p> <ol style="list-style-type: none"> 1. Go to the menu with the MENU / OK button. 2. Press the BROWSE button until the AUTO CONF. led is lit. 3. Press the SET button until the value you wish to select shows in the display. <p>For example 1 = Automatic configuration is on.</p> <p>The automatic configuration settings are changed.</p>			
<p>5 TEST SELECT</p>	<p>Use this setting to choose between automatic and manual tests.</p> <p>7-segments-display</p> <table border="1" data-bbox="639 831 970 936"> <tr> <td style="text-align: center;">1</td> <td style="text-align: center;">2</td> <td></td> </tr> </table> <ul style="list-style-type: none"> • The first section in the 7-segment-display determines every how often the luminaire test is made, from 1 to 7, meaning the number of days. If the number is 1, the test is made every day, or if it is 7, the test is done once a week. • The number of the second segment determines the settings of the luminaire tests. <p>0 = Luminaire and battery test, both manually.</p> <p>1 = Luminaire and battery test, both automatically (presumption).</p> <p>2 = Luminaire test automatically, battery test manually.</p> <p>3 = Luminaire test manually, battery test automatically.</p> <p>The automatic luminaire test is made once per day on the chosen time of the day.</p> <p>The automatic battery test is made twice a year (4th of January and 4th of July).</p>	1	2		<p>To choose between automatic and manual tests,</p> <ol style="list-style-type: none"> 1. Go to the menu with the MENU / OK button. 2. Press the BROWSE button until the TEST SELECT led is lit. 3. Press the SET button until the value you wish to select shows in the display. <p>The testing settings have been changed.</p>
1	2				

<p>6 SENSITIVITY</p>	<p>Use this option to set the limit for the current variation, if the central battery unit is set to work in circuit monitoring mode. The setting is +/- 80 mA as a standard.</p>	<p>To define how much the current can change before an alarm is issued,</p> <ol style="list-style-type: none"> 1. Go to the menu with the MENU / OK button. 2. Press the BROWSE button until the SENSITIVITY led is lit. 3. Choose the current value with the SET button. <p>As a standard the value is 16 = 160 mA divided by two, which gives +/- 80 mA.</p> <ol style="list-style-type: none"> 4. Browse with the SET button the value of the current can be changed all the way up to +/- 150 mA. <p>In the display this shows as the value 30. When the value 30 is exceeded, the following value is the minimum current the change of which the central battery unit notices. The minimum value is +/- 40 mA. In the display this will be shown as the number 8.</p> <p>NOTE: In parallel connection the current values are multiplied by the number of the parallel connected circuits. 700 W = 2x or 1400 W = 4x.</p>
<p>7 LUMI. TEST TIME</p>	<p>Use this option to choose a time for the automatic luminaire test, in full hours.</p>	<p>To change the luminaire test time,</p> <ol style="list-style-type: none"> 1. Go to the menu with the MENU / OK button. 2. Press the BROWSE button until the LUMI. TEST TIME led is lit. 3. Press the SET button until the value you wish to select shows in the display. <p>For example 15 = 15:00 = 3 pm</p> <p>The luminaire test time has changed.</p>

<p>8 DELAY TIME</p>	<p>Use this option to select a 0 to 15 minute delay when switching from battery use to mains voltage use.</p> <p>This function works only when the mains supply has failed and then returned. The delay is needed if mercury vapour lamps or similar luminaires whose ignition requires a longer time are used as general luminaires.</p> <p>As a default setting there is no delay. The number display shows the delay in minutes.</p>	<p>To change the delay time,</p> <ol style="list-style-type: none"> 1. Go to the menu with the MENU / OK button. 2. Press the BROWSE button until the DELAY TIME led is lit. 3. Press the SET button until the value you wish to select shows in the display. <p>The delay time has changed.</p>
<p>9 CENT. NUMBER</p>	<p>Use this selection to choose an individual number for the central battery unit.</p> <p>The number is printed on the report and so the information on the reports can always be linked to a specific central battery unit, if there are more than one central battery units in the building.</p>	<p>To set an individual number for the unit,</p> <ol style="list-style-type: none"> 1. Go to the menu with the MENU / OK button. 2. Press the BROWSE button until the CENT. NUMBER led is lit. 3. Press the SET button until the value you wish to select shows in the display. <p>The individual number has been assigned.</p>
<p>10 BATT. LEVEL</p>	<p>Normally, this value doesn't need to be changed.</p> <p>Use this option to change the level of the battery voltage at which the battery test is stopped.</p> <p>As a default the voltage level is 210 V. Number 10 is programmed to be added in the number 200 programmed, so the voltage will be 210 V. As a default there is number 10 in the display, which means this battery voltage of 210 V. The limit that is reached first ends the test. The time and the end voltage are recorded.</p>	<p>To change the voltage limit for a battery test,</p> <ol style="list-style-type: none"> 1. Go to the menu with the MENU / OK button. 2. Press the BROWSE button until the BATT. LEVEL led is lit. 3. Press the SET button until the value you wish to select shows in the display. <p>The voltage limit has been changed.</p>

11 DURATION	Use this option to select a 1 h or 3 h battery mode operating time.	<p>To change the battery mode operating time duration,</p> <ol style="list-style-type: none"> 1. Go to the menu with the MENU / OK button. 2. Press the BROWSE button until the DURATION led is lit. 3. Press the SET button until the value you wish to select shows in the display. <p>The operating time has been changed.</p>
12 YEARS	<p>Use this option to set the year.</p> <p>The year is set by selecting the last two digits of the year, 00...50 (e.g. 09 = 2009).</p>	<p>To set the system time and date,</p> <ol style="list-style-type: none"> 1. Go to the menu with the MENU / OK button. 2. Press the BROWSE button until the right led is lit. 3. Press the SET button until the value you wish to select shows in the display. 4. Acknowledge by pressing the MENU / OK button again. <p>The system time and date have been set.</p>
13 MONTHS	<p>Use this option to set the month.</p> <p>The number of the month is set, 1...12.</p>	
14 DAYS	<p>Use this option to set the day.</p> <p>The number of the day is set, 1...31.</p>	
15 HOURS	<p>Use this option to set the hour.</p> <p>The hours are set, 0...23 (0 = midnight, 12 = midday).</p>	
16 MINUTES	<p>Use this option to set the minutes.</p> <p>The minutes are set, 00...59.</p>	

Note! If both battery and mains are disconnected, the factory defaults are restored and the control unit needs to be reconfigured.

4.10 Control Module panel test functions and alarms

LED	Description	Instruction
BATTERY TEST	<p>As a basic setting, the battery test is done automatically twice a year: on the 4th of July and on the 4th of January, at 12 pm (midnight).</p> <ul style="list-style-type: none"> • If the LED is continuously lit, the battery test is in progress. • If the LED is flashing, an error has been detected in the battery test. In this case the <i>External fault</i> LED will also be lit. <p>During the battery duration test, the central battery unit is switched to battery mode and all output circuits are switched on.</p> <ul style="list-style-type: none"> • If the LEDs <i>Internal fault</i> is lit and <i>Battery test</i> is flashing, the battery duration test has failed. <p>A change of battery always requires a new configuration, so that the software knows a battery has been replaced.</p> <p>The battery test can be started by pressing one button on the control unit interface, or manually using the control unit menu.</p>	<p>No action needed, unless the test fails. If the test fails check condition of batteries</p> <p>To run the battery test yourself, either</p> <ol style="list-style-type: none"> 1. Press the BROWSE button for 8 seconds. <p>or</p> <ol style="list-style-type: none"> 1. Press the MENU / OK button. 2. Use the BROWSE button to select 2, TESTING. 3. Use the SET button to select 3, battery test during 2/3 of the operation time. 4. Accept the selection with the MENU / OK button. <p>The battery test starts.</p>
LUMINAIRE TEST	<p>If the LED is continuously lit, the luminaire test is in progress.</p> <p>If the LED is flashing with <i>External fault</i> LED, configuration is in progress.</p> <p>Luminaire test must be carried out once in 1-7 days. Factory setting is once a day at midnight (00.00 o'clock).</p>	<p>No action needed, unless the test fails. If the test fails check condition of luminaires.</p> <p>To run the luminaire test yourself, either</p> <ol style="list-style-type: none"> 1. Press the BROWSE button for 3 seconds. <p>or</p> <ol style="list-style-type: none"> 1. Press the MENU / OK button. 2. Use the BROWSE button to select 2, TESTING. 3. Use the SET button to select 1 = Starting the luminaire test. 4. Accept the selection with the MENU / OK button. <p>The luminaire test starts. If a faulty luminaire was found in any of the circuits, its corresponding LED will</p>

		<p>flash when its circuit number is shown on the display.</p> <p>If luminaire test will not start, check battery voltage level. It must be more than 200 VDC.</p>
LOCAL CONTR. ALARM	<p>The central battery unit can be remote controlled to send a local controller pulse to all circuits, in which case all the non-maintained addressable luminaires (Teknoware types ending with -K, or external luminaires fitted with Teknoware address module) that are connected to the central battery unit are switched on. This feature can be activated by opening loop 68-69.</p> <ul style="list-style-type: none"> • If the LED is lit, the loop 68-69 is open. • If the LED is blinking slowly, K-model luminaires are turned on from the menu with AC voltage. 	<p>Check the loop between connectors 68-69.</p>
FUSE FAULT	<ul style="list-style-type: none"> • If the LED is lit, there is a faulty fuse in the control module. • If the LED is blinking slowly, there is a faulty fuse in the circuit shown on the display. • If the LED is blinking quickly, there is some other fault in the circuit shown on the display. 	<p>Check all circuit output fuses.</p>
EXTERNAL FAULT	<p>Alarms when an external fault is detected in the battery or the luminaire, the battery or the luminaire test has failed.</p> <p>If the LED is flashing with <i>Luminaire test</i> LED, configuration is in progress.</p>	<p>Check that all luminaires are working.</p>
INTERNAL FAULT	<p>If the LED is lit continuously, there is a fault in the battery or charging circuit. i.e. the alarm is coming from the Central Module</p> <p>If the LED is flashing, there is a fault in a circuit output fuse or output circuit</p>	<p>Check if battery or charger is faulty. Measure voltage level of batteries. In normal situation it should be 243-255 VDC.</p>

4.11 Buttons

MENU / OK	Used for selecting a menu or accepting a selection. Used for starting tests and/or printing.
BROWSE	Used for browsing menus and making selections within the menu.
SET	Used for changing a desired setting in the menu. Press for 3 seconds to start luminaire test. Press for 8 seconds to start battery test.
1 s V-METER	Press and hold SET for 1 second: the voltage of the battery is displayed in the LCD display
2 s DC A-METER	Press and hold SET for 2 seconds: DC discharge current from the battery
4 s LUMIN. TEST	Press and hold SET for 4 seconds: start of the luminaire test
6 s BATT. TEST	Press and hold SET for 6 seconds: start of the battery test

5. System planning and installation

5.1 System planning

Tapsa Control central battery unit uses the circuit cabling to transfer data between the central battery unit and the luminaires. This way there is no need for separate data cabling, and the circuit cabling can be done in the same way as the regular cabling for emergency lighting system.

5.1.1 Luminaire-specific addressable monitoring

The following points should be taken into consideration when planning addressable monitoring:

- The luminaires used in the system must be manufactured by Teknoware, and their type code must end with a 'K' (For example TWT6081K) or external luminaires fitted with Teknoware address module. These types of luminaires include the technology that allows communication between the luminaire and the central battery unit.
- The luminaires must be coded with addresses from 1 to 32. The addresses can be selected freely as long as two or more luminaires in the same circuit do not have the same address. The coding (circuit no. / luminaire no.) can be marked in accordance with the electrical plan to the address label delivered with the luminaire.

5.1.2 Circuit monitoring

Circuit-specific condition monitoring allows the usage of any emergency luminaires operating on AC/DC voltage. However, in case of the fluorescent lamp luminaires, they shall be designed so that they switch off when the lamp fails. This is because the system measures only the current of the circuit and detects the failures from the changes in it.

5.2 System installation

The system must be installed according to the electrical plan or work description.

If you use addressable monitoring, make sure that all luminaires belonging to the same circuit have a different address number (between 1 and 32). Set the address by changing the DIP switch settings. The DIP switch is located in the data transfer unit or electronic ballast inside the luminaire. The instructions for setting the addresses are included in the luminaires' installation instructions.

To install the system,

1. Make sure that the main switch is in the '0' position and the battery fuses are removed.

The batteries are always placed in a separate battery case, and connected in series (18 x 12 V) to the + (red) and - (black) cables reserved for them. The batteries' temperature sensor is placed between the batteries.

2. Check the polarity of the batteries.
3. Connect the supply cable to connectors 1~ L, PE and N or 3~ L1, L2, L3, PE and N (F-models)
4. The output circuits are connected to connectors X1-X3.

The circuit fuses F1-F24 are located at connectors X1-X3. The central battery unit outputs can be connected as maintained or non-maintained, using the "Mode" wire links in the following way:

"Mode" link closed	Maintained emergency luminaire circuit (exit luminaire)
"Mode" link closed	Maintained emergency luminaire circuit (when using Local Controllers) Or, while connecting Local Controllers and/or K-model maintained or non-maintained emergency luminaires to a same circuit. Or, while connecting maintained luminaires without Control function and K model luminaires to a same circuit
"Mode" link open	Non-maintained emergency luminaire circuit

As factory setting, all circuits are connected as maintained (exit luminaire or Local Controller). If you wish to change into non-maintained emergency luminaire circuits, the "Mode" link needs to be removed from those circuits. Layout for "Mode" links is in next chapter.

NOTE! If you have control type luminaires (model type ends with letter K) or address modules with maintained/non-maintained selection, all mode links can be closed. Luminaire will be selected maintained or non-maintained with DIP –switch. See further information from luminaire's operation manual.

5. Connect the alarms and the remote control switch into the connectors shown in *APPENDIX 4* and *APPENDIX 5*.
6. Set the system date on time so that the automatic tests can take place when scheduled (factory setting at 00.00 o'clock)

5.2.1 Parts layout

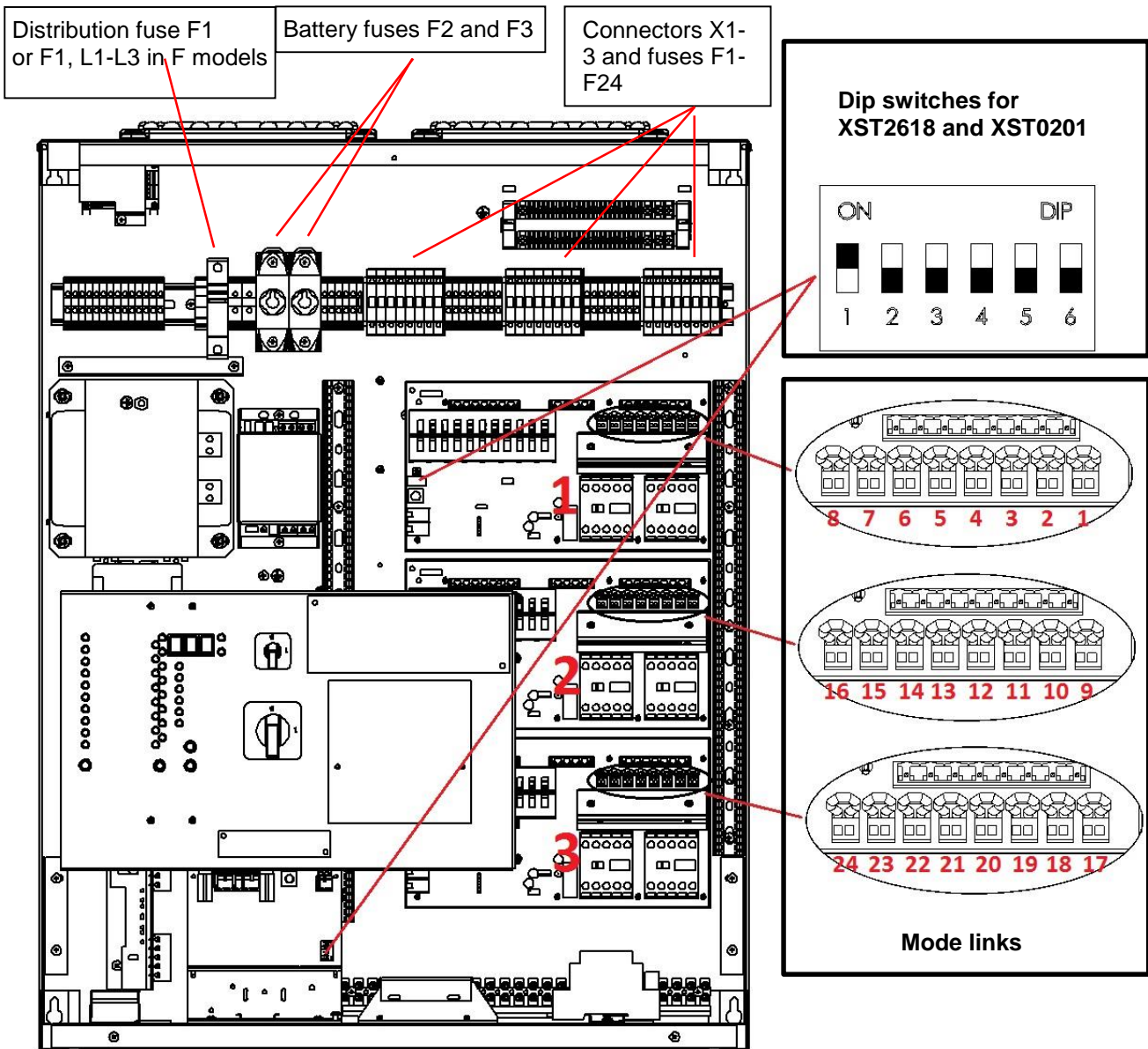

5.2.2 Circuit wiring in parallel connection

700 W (2 circuits combined) parallel connection wiring for circuit board 1

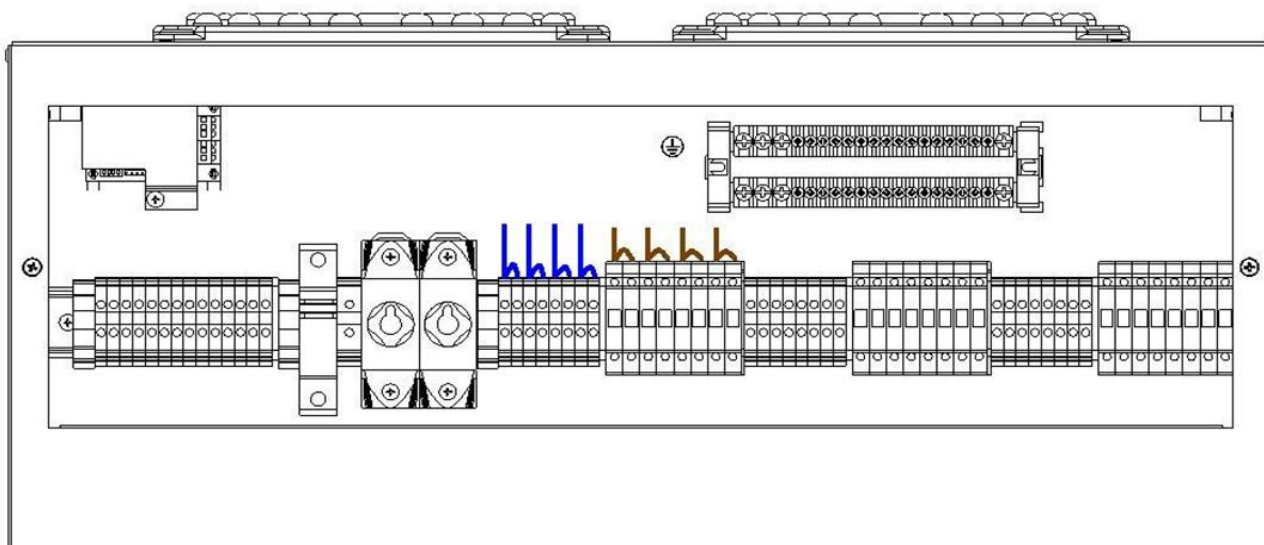

1400 W (4 circuits combined) parallel connection wiring for circuit board 1

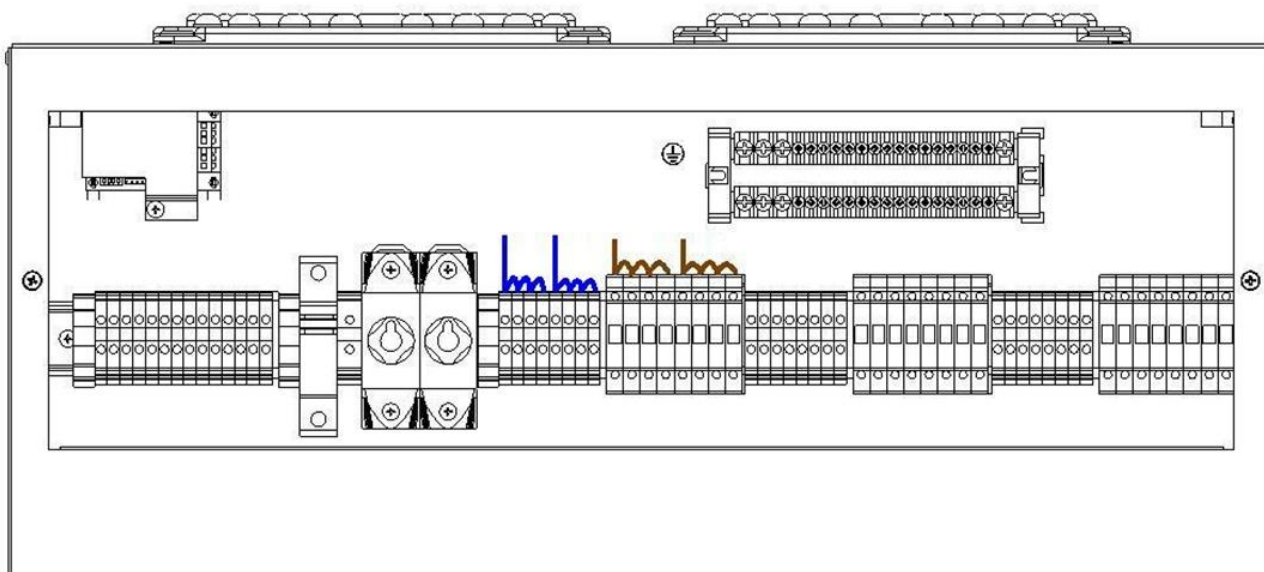

Note! If you are using parallel connections please note that all output circuits in same change over board has 700 W or 1400 W outputs. The next chapter has an explanation how to set the changeover board to a parallel connection mode.

5.2.3 DIP switch settings in circuit boards

The DIP switch number 4 must be used to select a desired operating mode for each board. When the DIP switch number 4 is in the 'OFF' position, the circuit board operates according to the addressable luminaire monitoring principle.

When the DIP switch number 4 is in the 'ON' position, the circuit board operates according to the circuit monitoring principle.

The factory setting for the circuit boards is addressable monitoring.

For more information, see Chapters 4.3 *Circuit board settings* and 4.4 *Parallel connection of output circuits*.

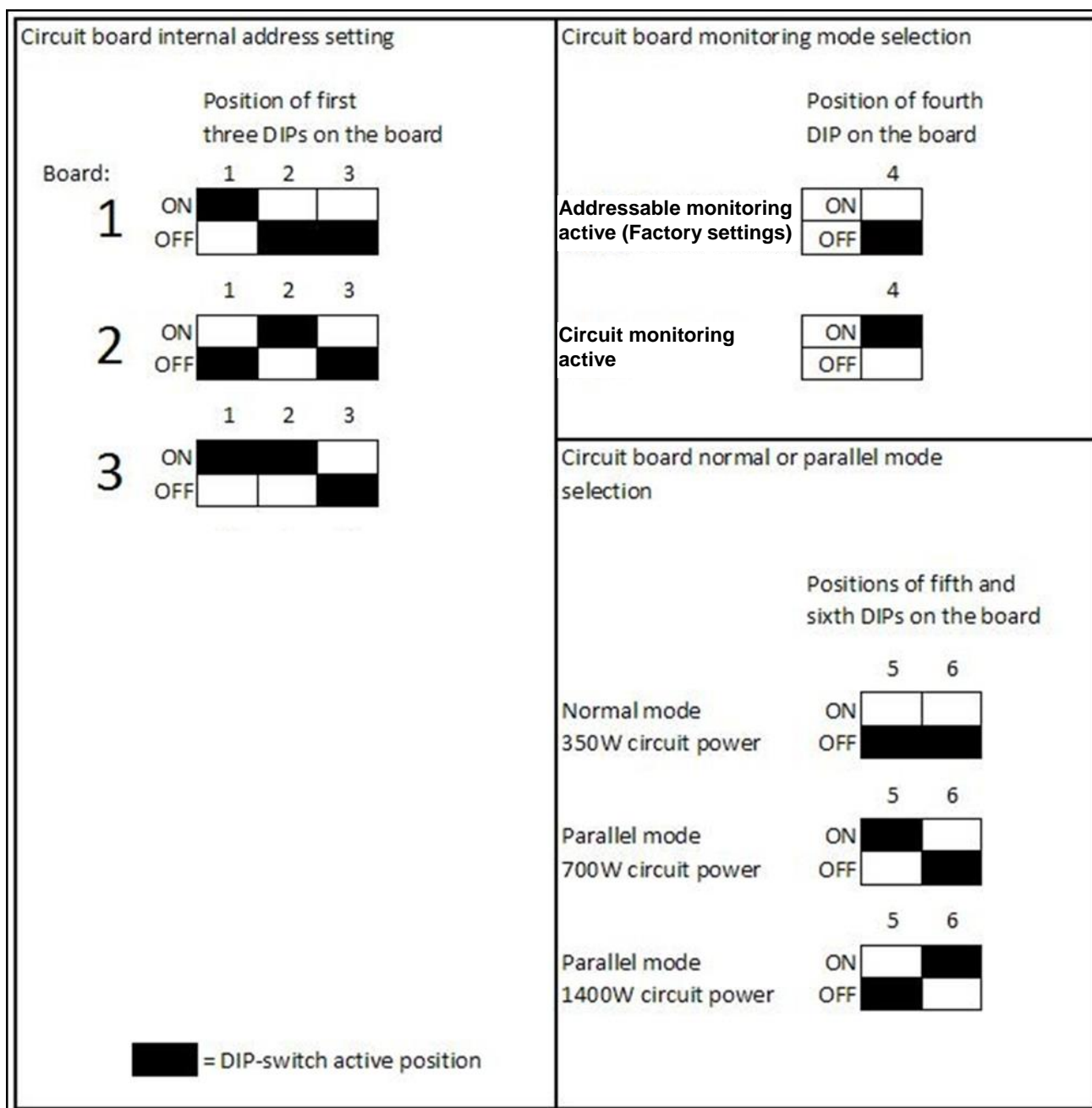

5.3 Commissioning

All operations related to the system installation and commissioning must be performed by a skilled electrician.

The two empty columns of the type label inside the central battery unit shall be marked with the total load connected to the central battery unit and the nominal battery mode duration.

5.3.1 Setting of battery capacity

The charging current has been set to minimum at the factory. The charging current must be set / checked as follows:

1. Set the current on the TS5 XST0201(B) DIP switch according to the guidelines in the illustration below.

NOTE: The charging current must ALWAYS be set / checked based on the number of ampere-hours (Ah) in the batteries used. Incorrect settings may damage the batteries. When all dip switches are set to 'OFF' position, the charging current is set correctly for 65 Ah batteries. Other battery sizes are as shown in the sticker. The sticker shows a setting for a 7 Ah charging current as an example.

NOTE: THE CHARGING CURRENT SHALL ALWAYS BE SET WITH MAINS SUPPLY OFF. ONLY ONE DIP SWITCH IS ALLOWED TO BE SWITCHED ON AT THE SAME TIME.

- 1 = 7 Ah
- 2 = 17 Ah
- 3 = 24 Ah
- 4 = 38 Ah
- ALL OFF = 65 Ah
- 5 = NC
- 6 = NC

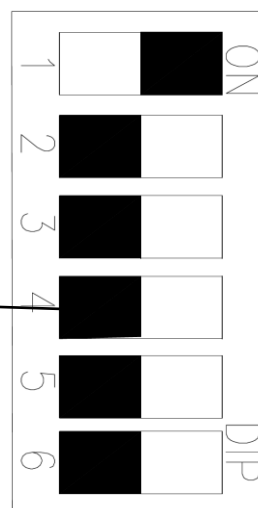
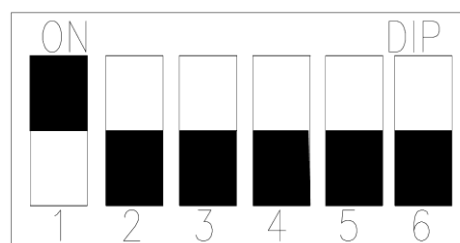
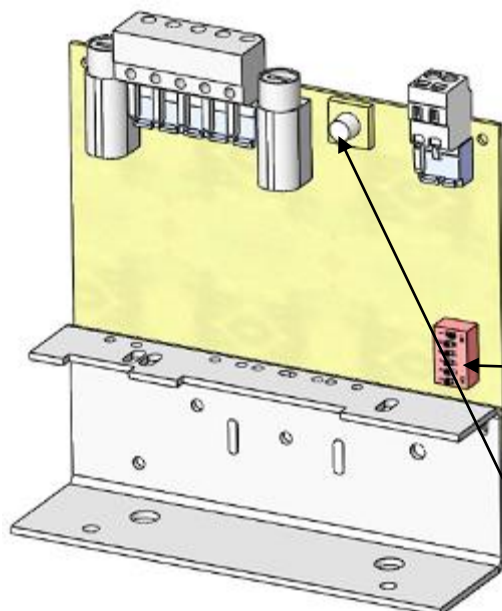

Forced charge button for batteries

5.3.2 Forced charging of the batteries



WARNING

Using forced charging button is live working and it must be done in accordance with live working declarations.

Before using the Forced charging of batteries, test each battery separately with a battery tester.

There is a button for forced charging in the charger board. If the battery voltage is under 110 V, push this button for 1-2 min and measure the battery voltage at the same time. Charging starts automatically when battery voltage rises up over 110 VDC. If the batteries, the main input voltage and all fuses are OK and the charger doesn't charge, it is broken. It has to be replaced with a new one.

5.3.3 Checking the luminaire circuits one at a time

The circuit-specific checking can be done using either addressable or circuit monitoring. The central battery unit can either be configured or not.

To checking the functionality of a single circuit,

1. Press the **BROWSE** button until the display shows the number of the circuit whose luminaires' functionality you want to check.
2. Press the **MENU / OK** button.
3. Use the **BROWSE** button to select 2, *Testing*.
4. Use the **SET** button to select 1 = Starting the luminaire test
5. Accept the selection with the **MENU / OK** button.

LED	Explanation
<i>Luminaire test</i> is flashing <i>External fault</i> is flashing	Checking luminaire circuits on at a time is running.

As the checking process progresses, the LEDs will show the luminaires found in the circuit or the total input power of the circuit. Once the test is complete, you can use the **BROWSE** button to have the central battery unit display the tested luminaire circuits and the luminaires detected in them or the total input power of the circuit.

5.3.4 Configuration

It is advisable to check before the configuration that all the luminaires are actually working, because the configuration will teach the functionality of the existing luminaires to the testing system. The learned configuration will then be used as a reference for all future tests.

NOTE: When CIRCUIT MONITORING is used, the central battery unit and the maintained luminaires must be allowed to warm up for at least one (1) hour before the final configuration. This is essential, because the warm-up time allows the luminaire currents to normalise.

The warm-up is carried out by running a luminaire test, as instructed under LUMINAIRE TEST in chapter 4.9, Control Module panel. The warm-up phase is not necessary when using addressable monitoring.

In addressable monitoring, the central battery unit sends inquiries to the circuits in order to determine the luminaires in the circuits.

In circuit monitoring, the central battery unit will wait for a few minutes and let the luminaires warm up before measuring the current in each circuit. The first luminaire test is automatically a configuration. The configuration cannot be interrupted. The results of later tests are compared with the configuration data.

Once the *Luminaire test* and *External fault* LEDs go off, the central battery unit is configured and has returned to normal mode. In normal mode, the display will show the information of each circuit one at a time. The information of each circuit will be shown for four seconds.

You can browse the circuit information with the **BROWSE** button.

After the central battery unit has configured itself, it will return to the *normal mode*.

6. Maintenance

The condition of the emergency lighting system must be ensured by regular maintenance according to the laws and regulations of local authorities.

In addition to the checks and inspections there is no regular maintenance required for the central battery unit, other than changing the batteries when the specified emergency mode duration is no longer achieved.

The luminaires need to have their light sources replaced once they have reached the end of their lifetime.

Only a qualified electrician may perform such maintenance operations which require opening of the casing of the central battery unit or the battery container.

6.1 Replacing the batteries

To replace the batteries,

1. Open the hatch of coupling space.
2. Remove the battery fuses F2 and F3 (see picture from chapter 5.2.1 *Parts layout*).

Mains operation and *Internal fault* LEDs will be lit.

3. Turn the S1 main switch and distribution fuse F1 to '0' position (see picture from chapter 5.2.1 *Parts layout*).

The display LEDs go off = the central battery unit is de-energized.

4. Remove the cover from the battery case(s).
5. Disconnect the cables coming from the central battery unit from the batteries.

Remove the minus cable first.

6. Remove the battery interconnection cables.
7. Pull the temperature sensor aside.
8. Lift off the batteries and replace them with new ones.
9. Place the batteries' temperature sensor between the batteries.

NOTE! Misplacing the temperature sensor may damage the batteries!

10. Connect the battery cables (pay attention to polarity and insulation distances).

11. Close the battery case cover(s).
12. Refit the battery fuses F2 and F3.
13. Turn the mains fuse F1 to '1' position.
14. Close the central battery unit cover.
15. Turn the mains switch to '1' position.
16. Carry out the system configuration according to the instructions in chapter *5.3.4 Configuration*.
If the configuration is interrupted, check the charge level of the batteries.
17. Make sure that the central battery remains in normal mode.

7. Disposal

Note the following issues regarding the disposal of the central battery unit system and its components:

Batteries and fluorescent lamps are hazardous waste. Metal parts can be put into aluminium or steel waste. Wires, connectors and printed circuit boards are electronics waste. The plastic parts shall be separated based on the material markings.

Follow the local laws and regulations in disposing the central battery unit system and its components.

8. Optional Features

Optional features are options that can be added to a central battery unit, depending on the model. You can either

- select a central battery unit that already includes the option, or
- select the option as an added feature, depending on the model.

The options are presented in Chapter *3.5 List of optional features*.

A sticker on the side of the central battery unit describes what optional features are included in your central battery unit.

8.1 LCD display functions

The LCD display, under the name of TST6632, is an option for central battery systems. The LCD displays the status of the central battery system, as well as stores test results in its memory. The following information is available on the LCD: battery set charge, battery voltage, date, time, results of battery tests and results of luminaire tests. The built-in memory of the LCD stores a two-year test history.

8.1.1 Button functions

The LCD has three buttons, the uppermost of which has two separate functions: if the button is pressed only briefly, it selects the current option; if it is pressed and kept pressed for 1.5 s, the previous menu is displayed. The middle and lowermost buttons are used for browsing for options and changing the value of the selected parameter.

8.1.2 LCD content

If the LCD has not been configured, it will display the status screen shown below. In a few minutes, it will receive configuration data from the central battery system, with the exception of luminaire circuits.

<p>???.???.???? ??:?? System status Voltage level xV Charge current xA</p>

Figure 1. LCD not yet configured

The first row shows the date and time in format: dd.mm.yy.hh.min. The date and time are provided by the central battery system; alternatively, they can be manually set on the LCD.

The second row shows the status of the central battery system.

NOTE: For error code explanations, please refer to the error log. See chapter 8.1.6 *Error log*.

The third row shows the voltage level of the battery set. The fourth row shows the battery set charge and discharge currents.

<p>23.03.2011 10:30 System status OK Voltage level 243V Discharge current 1.0A</p>

Figure 2. LCD after having received configuration data from the central battery system

8.1.3 LCD menu tree

When you press the **SETUP** button, the LCD menu tree is displayed. You can browse the menu by pressing the +/- buttons. You can select four separate submenus from the menu. The submenus are shown in Figure 3.

The luminaire test log contains a two-year test memory, or, alternatively, the test memory of the latest 730 tests.

The battery test log contains a two-year test memory, or, alternatively, the log of the latest 256 tests. The error log contains entries for the latest 42 errors.

You can use the **SETUP** button to change the date and the time of the day, as well as start a luminaire/battery test.

<p>Browse luminaire tests Browse battery tests Browse error log Setup</p>

Figure 3. Main menu

8.1.4 Test history

When you select **Browse luminaire tests**, the display below is shown.

<p>Luminaire test log 23.03.11 23:59 OK 22.03.11 23:59 ERROR</p>

Figure 4. Luminaire test log

The example shows a test date and time, as well as the test result, **OK** or **ERROR**. You can browse the log by pressing the **+/-** buttons. If you want to view the test results for a particular date, use the **+/-** buttons to select the desired date, and then accept your selection by briefly pressing the **SETUP** button. To move back to the higher-level menu from the test log, press the **SETUP** button.

A central battery system may house 1 to 3 changeover boards, each with 8 outputs. Each output circuit may have 32 luminaires, shown in displays 16 LO and 16 HI. If only 16 luminaires are available, HI and LO are not shown in the display. If the central battery system makes use of more than one change over boards, you can select the data for a desired board by first pressing the **+/-** buttons and then confirming your selection by pressing the **SETUP** button. The symbols used in the display indicate the following.

O = OK

= Error

? = Luminaire not recognised (a luminaire has been added; automatic configuration is not in operation)

- = Luminaire is not connected

```
Test 23.03.2011 10:30
Change over board 1-#OO.....
Change over board 2-OO.....
```

Figure 5. Luminaire tests with change over boards

The "1- #OO" symbol for changeover board 1 indicates an error in output circuit 1.

The "2- OO" symbols for changeover board 2 indicate that output circuit 2 has no errors.

If you want to view the data for a particular changeover board, first select the board using the **+/-** buttons, then confirm your selection by pressing the **SETUP** button. To move back to the higher-level menu from the test log, press the **SETUP** button for 1.5 s.

You can use the data display for change over boards to view data for any output circuit. You can browse the output circuits by pressing the **+/-** buttons. To view the data for luminaires, press the **SETUP** button. If the luminaires have been given names using a PC programme, the names are shown on the last line. To move back to the higher-level menu from the test log, press the **SETUP** button for 1.5 s.

```
CHANGE OVER BOARD 1, OUTPUT CIRCUIT>1
HI: OOOOOOOOOOOOOOOO
LO: O#OO.....
```

Figure 6. Luminaire tests, output circuit data

The dots indicate a vacant address, O = OK and # = ERROR. Twenty luminaires have been interconnected to provide service in a output circuit, with luminaire 2 malfunctioning (LO 2).

8.1.5 Battery test history

You can browse the battery test log for detailed information on battery tests. You can view battery test results, if the central battery systems has performed an automatic battery test, or if a manual test has been carried out. The battery test log contains test dates, test times and test results. If you want to view the data for a particular battery test, first select the desired date using the **+/-** buttons, then confirm your selection by pressing the **SETUP** button. To move back to the higher-level menu from the test log, press the **SETUP** button for 1.5 s.

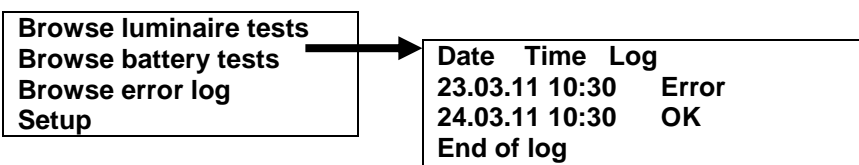

Figure 7. Main menu Browse battery tests

The log shows the date, time and duration of the test, as well as the voltage of the battery set at the end of the test. To move back to the higher-level menu from the test log, press the **SETUP** button for 1.5 s.

Date	Time	Log
23.03.11	10:30	Error
Battery test duration 01:25		
Battery set voltage 221V		

Figure 8. Luminaire test log

8.1.6 Error log

In addition to the log of the luminaires and battery tests, the display shows an error log of all errors detected in the central battery system. The log shows the date and time of each error, as well as a corresponding error code. If you want to view the data for a particular log, first select the desired log using the **+/-** buttons, then confirm your selection by pressing the **SETUP** button. To move back to the higher-level menu from the test log, press the **SETUP** button for 1.5 s.

Browse luminaire tests	→	Date	Time	Error
Browse battery tests		>23.03.11	10:30	2
Browse error log		23.03.11	10:32	5
Setup		22.03.11	00:15	2

Figure 9. Error log

Error code:	Error description:
1	Internal error
2	External error
3	Central battery system has not been configured
4	Internal and external error
5	Fuse fault or other malfunction in output circuit
6	Deep discharge
7	Error with changeover board
8	Overload

To move back to the higher-level menu from the test log, press the **SETUP** button.

8.1.7 Setup

You can change the settings and start tests by first selecting the desired function using the **+/-** buttons and then confirming your selection by pressing the **SETUP** button. Using the Setup display, you can start a battery or luminaire test, as well as set the date and time. Once you have started a battery test, you can cancel it by pressing the **SETUP** button and then selecting *Stop battery test*.

You can start a luminaire test by selecting *Start luminaire test*. The first luminaire test will configure the central battery system.

You can set the date and time by selecting *Set date and time*. In the clock settings, a blinking cursor identifies a value that you can change with the **+/-** button. You can change the parameter whose value you want to change by using the **SETUP** button. Once you have set the date and time, you can leave the menu by pressing the **SETUP** button, after which the new settings will be stored in the central battery system in a matter of few seconds.

To move back to the higher-level menu from the test log, press the **SETUP** button for 1.5 s.

NOTE: A battery test cannot be started unless the battery set is sufficiently charged.

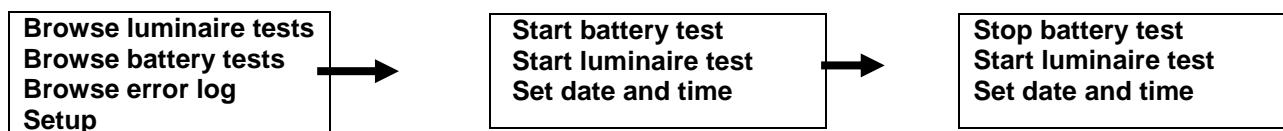

Figure 10. Settings and starting a test

8.1.8 External USB connection

A USB port on the LCD allows data entered in a separate PC programme to be transferred to the LCD. Using the PC programme, luminaires can be given names, along with descriptive information. Connect the LCD to the PC using a USB cable. Once you have connected the cable to the LCD, the following display is shown:

PC connected
Data transfer speed 1200

Figure 11. USB cable connected

The LCD software will scan the USB ports, opening a connection. A new row will appear on the display, informing you that a connection has been opened. The connection is now open.

PC connected
Data transfer speed 1200
Connection opened

Figure 12. Connection opened

The buttons on the LCD cannot be used if there is an active USB connection between the LCD and the PC. For more information, please refer to the PC programme user's guide.

8.2 Printer

The central battery units of the type Tapsa Control TKT66xxCD(L) or optional feature TST6631 are equipped with a printer. The results of the last test can be printed using the menu options as follows:

Press the **MENU / OK** button.

Use the **BROWSE** button to select 1, *Report*.

Use the **SET** button to select 1, Print a report of all circuits.

Accept the selection with the **MENU / OK** button.

The report can be attached to the central battery unit's logbook as a proof of a completed test.

8.2.1 Language selection of the printer (TKT66xxC(N)D(L)) or optional feature TST6631

It is possible to switch the language of the printing with the DIP switches of the TST3004 unit. The TST3004 contains the pre-programmed languages English, Finnish, Swedish and German. English is pre-selected in the factory.

The language is chosen with the DIP switches (1 and 2).

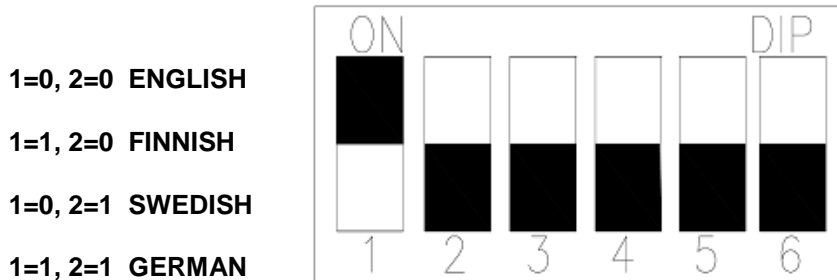

8.2.2 Printing out test reports

The results of the last test can be printed by using the menu options.

To print out the results,

1. Press the **MENU / OK** button.
2. Use the **BROWSE** button to select 1. *Report*
3. Use the **SET** button to select 1. *Print a report of all circuits*.
4. Accept the selection with the **MENU / OK** button.

The report can be attached to the central battery unit logbook to indicate a completed test.

APPENDIX 1: Report Layout

Title information

CENTRAL BATTERY UNIT 01				
00.00.2010 00:00				
CIRC. LUMINAIRE MONITORING	A	B	C	D mA
01-Lo 0000 0000 00.. ..	-	-	-	360
02-Lo 0000 0000 00.. ..	-	-	-	380
03-Lo 0000 0000 00.. ..	-	-	-	390
04/Lo .0.. ..	-	-	-	320
\Hi ..00 0000 00.. ..				
05-Lo 0000 00.. ..	-	-	-	470
06-Lo .000 00.. ..	-	-	-	400
07-Lo 0000 00.. ..	-	-	-	430
08-Lo 0000 00.. ..	-	-	-	440
CIRC. CIRCUIT MONITORING	A	B	C	D mA
09-P- ...0 0000 0000 0000	-	-	-	360
10-P- ...0 0000 0000 0000	-	-	-	380
11-P- ..00 0000 0000 0000	-	-	-	390
12-P-000 0000 0000	-	-	-	310
13-P- 0000 0000 0000 0000	-	-	-	460
14-P- ..00 0000 0000 0000	-	-	-	390
15-P- .000 0000 0000 0000	-	-	-	420
16-P- .000 0000 0000 0000	-	-	-	420
DISCHARGE CURR. 01.20A				
BATT. VOLTAGE 249V				
LUMINAIRE TEST	OK			00.00.00
BATTERY TEST	OK	00min		00.00.00
SYSTEM TEST	OK			
SETTING				
Auto conf	1	A=Local Contr.1		
Test Selection	1/1	B=Overload		
Sensitivity	080mA	C=Fuse		
Test Duration	24:00	D=Output Switch		
Connect. Delay	00min	O=OK		
Battery Level	210V	#=Faulty		
Operation time	060min			
STATUS	110800emd			

The input current of the circuit

Lo = addresses 1-16

Hi = addresses 17-32

P = Circuit monitoring

In circuit monitoring the strength of the current is shown from right to left

→ Current of all circuits in battery use

→ Voltage of battery on time of printing

→ Result and date of last luminaire test

→ Result and date of last battery test

→ Fault in central module, battery or charging circuit

→ Automatic configuration ON

→ Test Selection 1/1 = Gap between test dates / selected automatic tests

→ Current-range of circuit monitoring

→ Selected time of day for luminaire test

→ Selected connection delay from battery use to mains use

→ Voltage with which automatic battery test will be stopped

→ Operation time of the central battery unit

→ Status message tells the status of the unit

Symbol explanations:

A= Local Controller Fault

B= Circuit Overload

C= Fuse Fault

D= Output Circuit Fault

O = OK

= fault

? =Unknown luminaire (added, automatic configuration not in use

• = Luminaire not connected

The condition of the fuses is monitored in real-time on mains operation. Blown fuses can be detected if there is any load on the circuit. Empty circuits are not inspected.

NOTE! Only maintained circuits can be monitored in real-time (MODE closed). An internal error alarm on a fuse error will be given as soon as the error is detected. The error information will be automatically reset when the fuse has been replaced with a new one.

The condition of the output circuits is checked only before the tests. The circuit voltages are checked at this time with an open and closed output circuit. Empty circuits are not inspected in this case either. An output circuit error results in an internal error alarm. In circuit monitoring the LEDs of the front panel and in the report the corresponding circles show the strength of the current of the circuit. The stronger the current of the circuit, the higher the LED column. The LED column grows higher starting from down to upwards.

APPENDIX 2: Mechanical dimensions

TKT66:

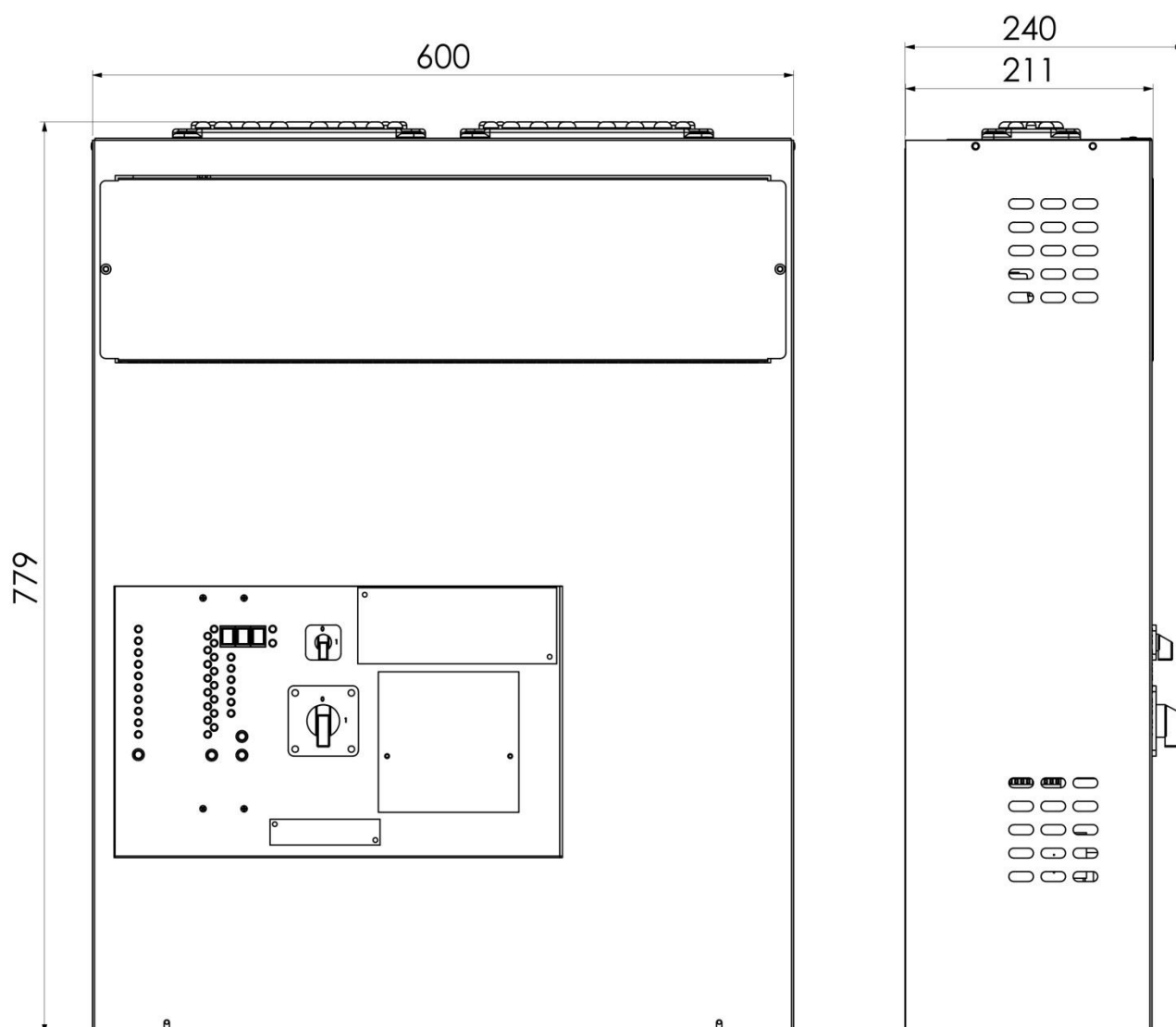

TKT66..P:

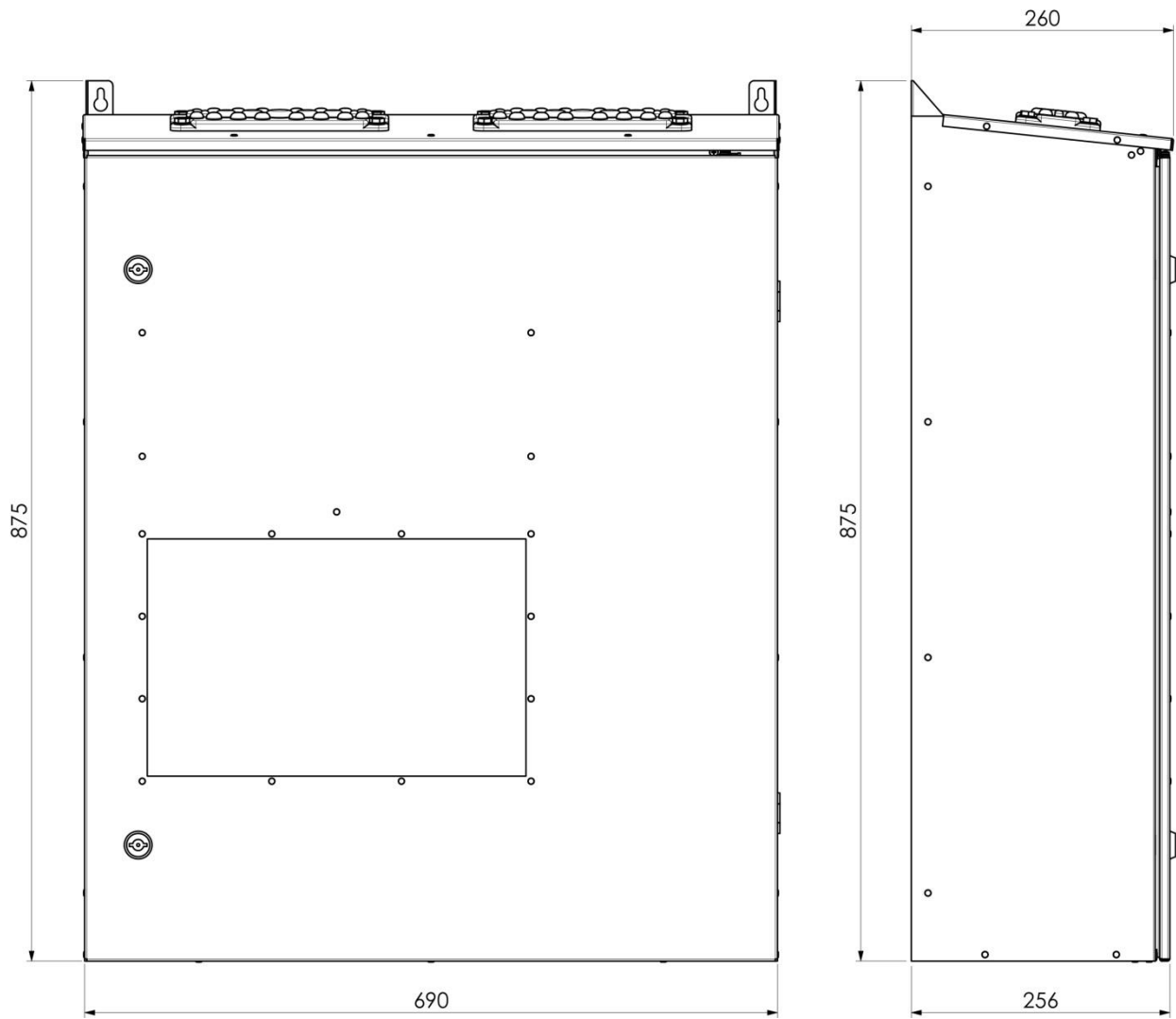

APPENDIX 4: Circuit diagram with 1-phase input and BCM connection

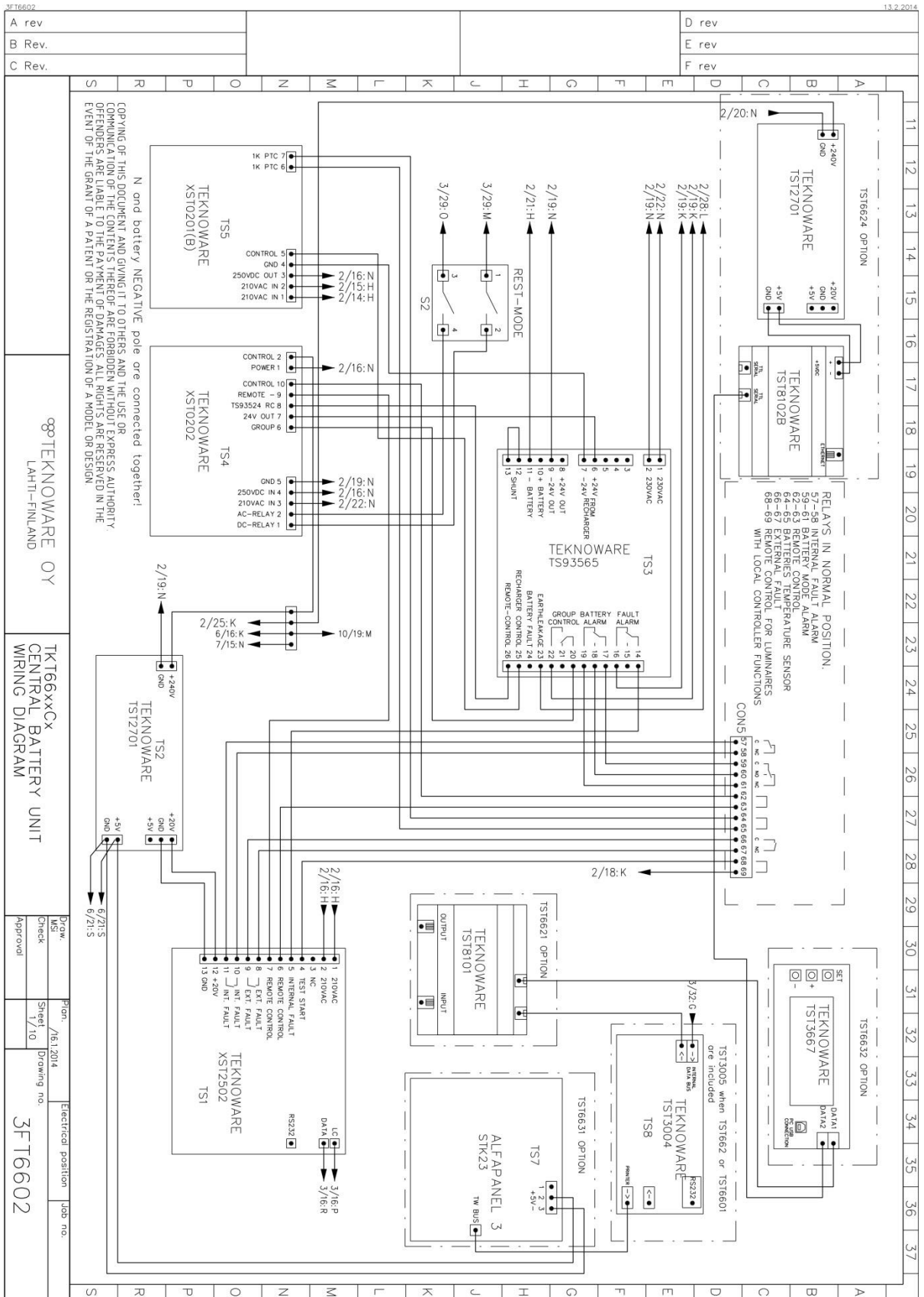

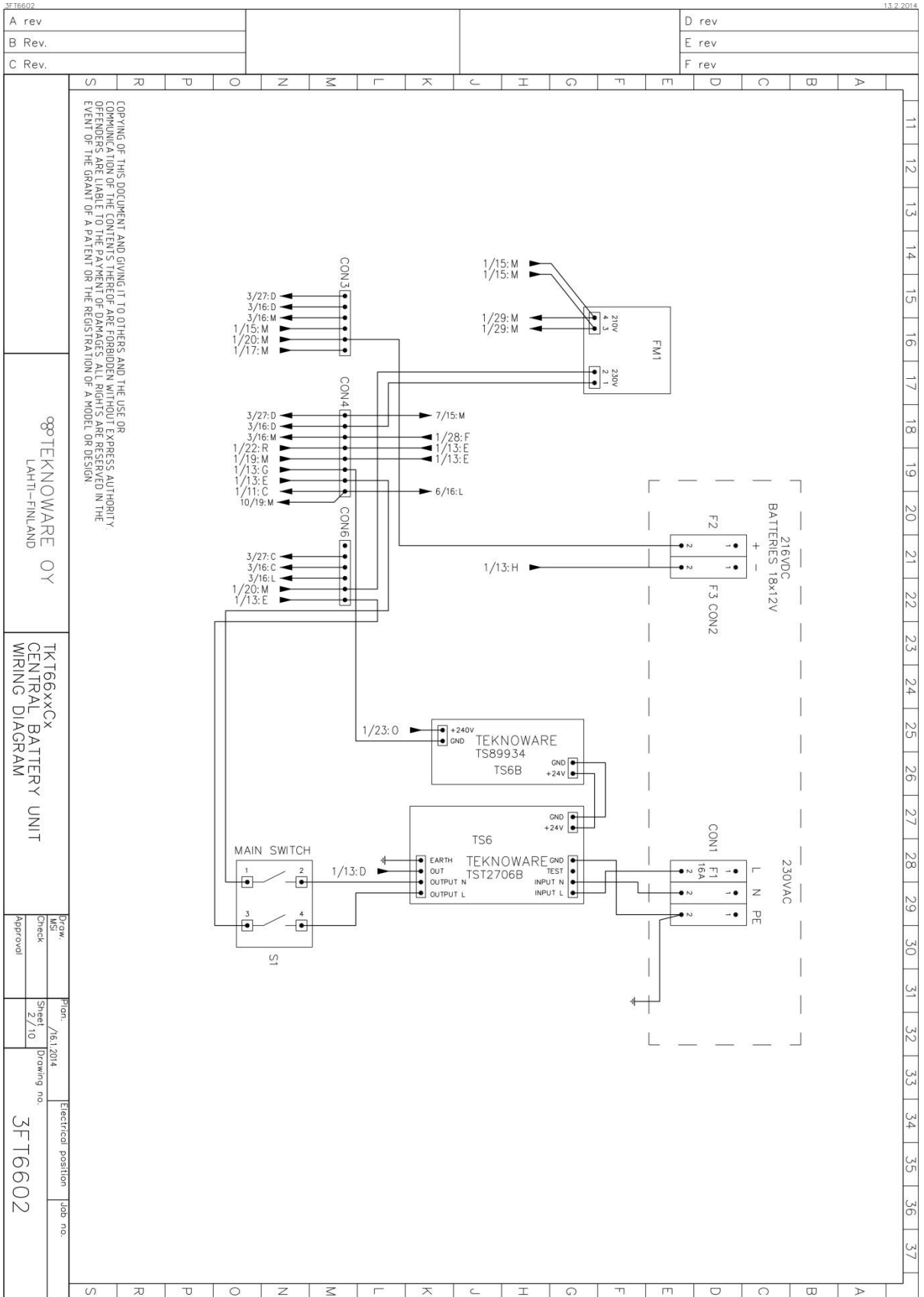

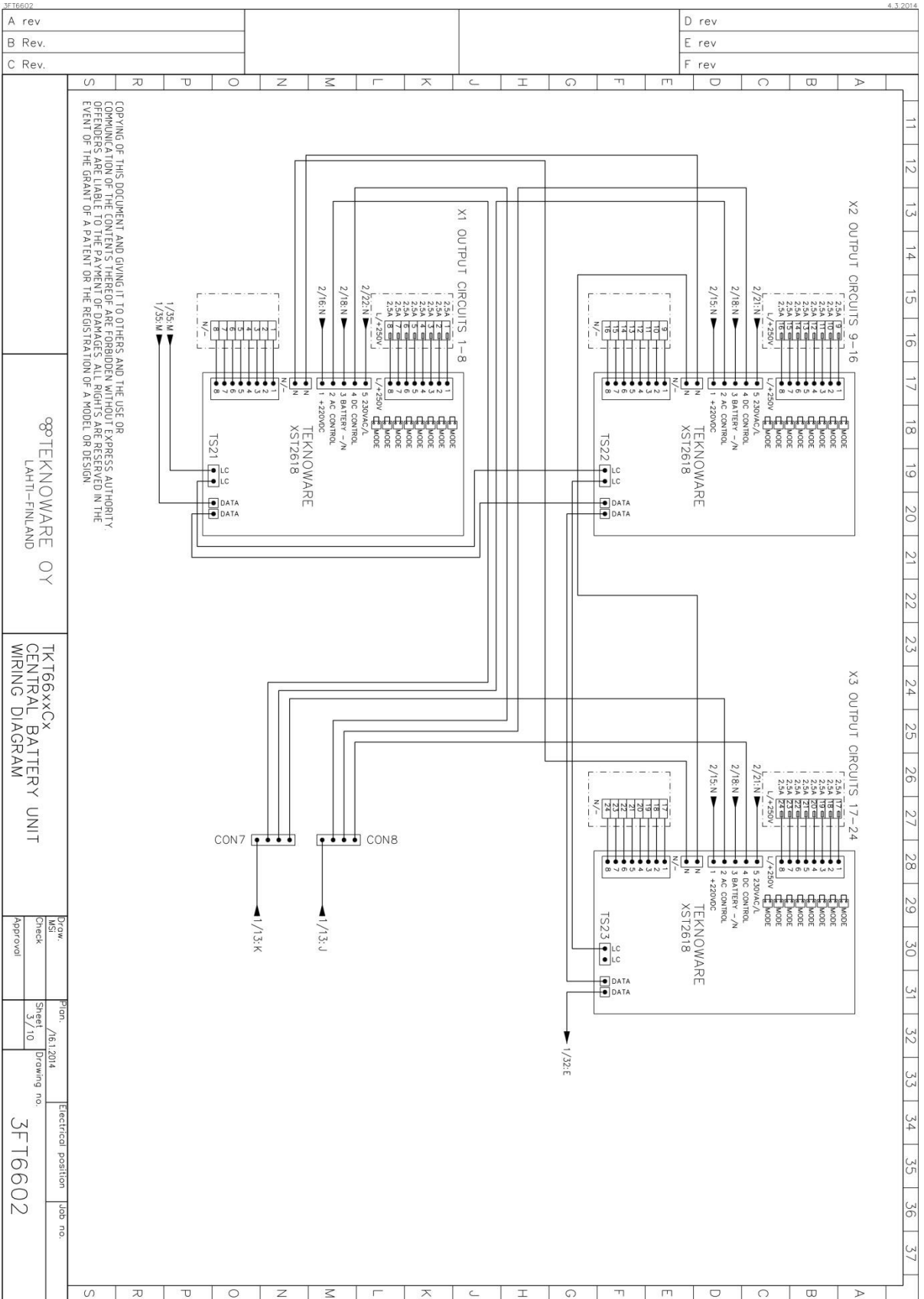

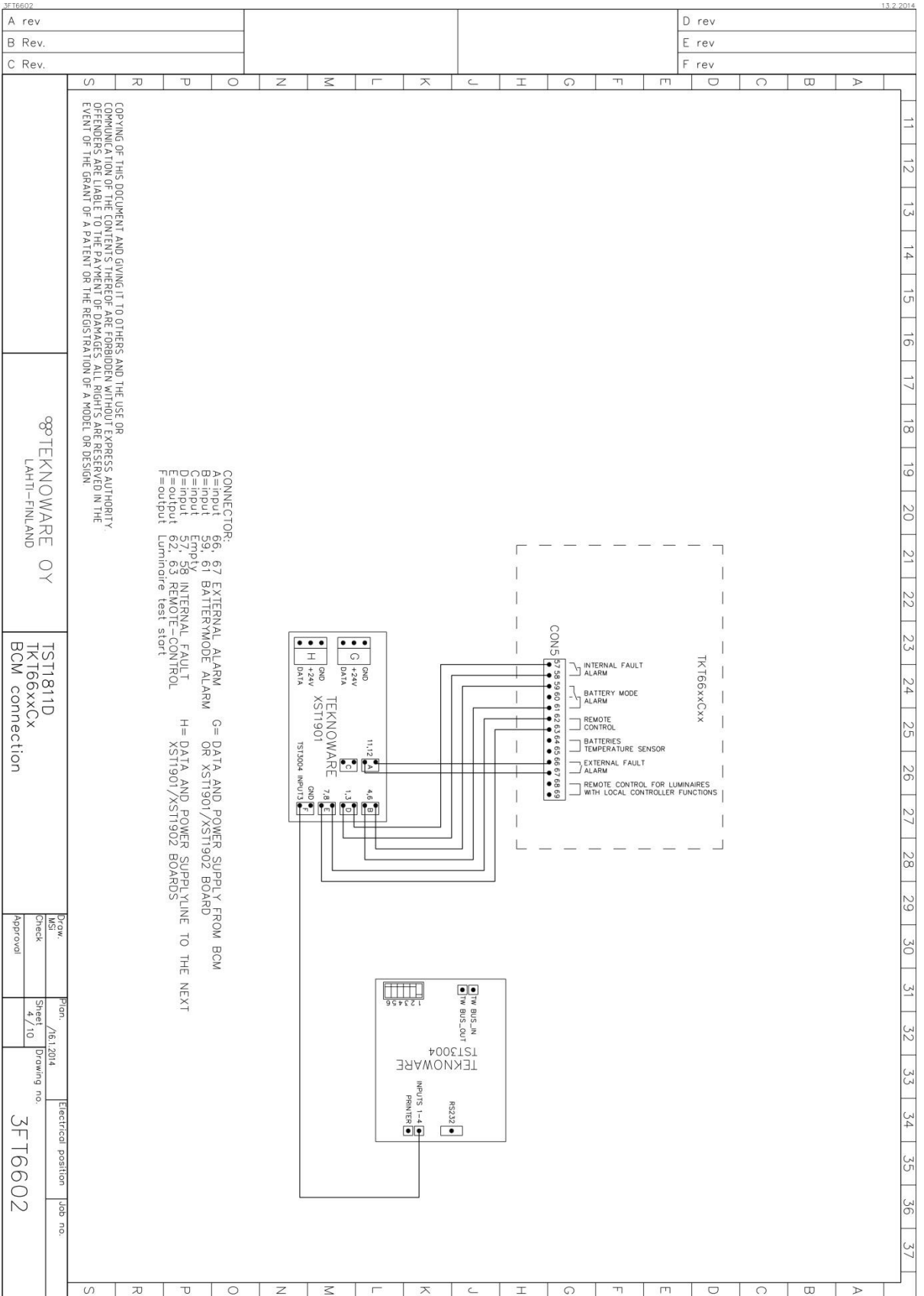

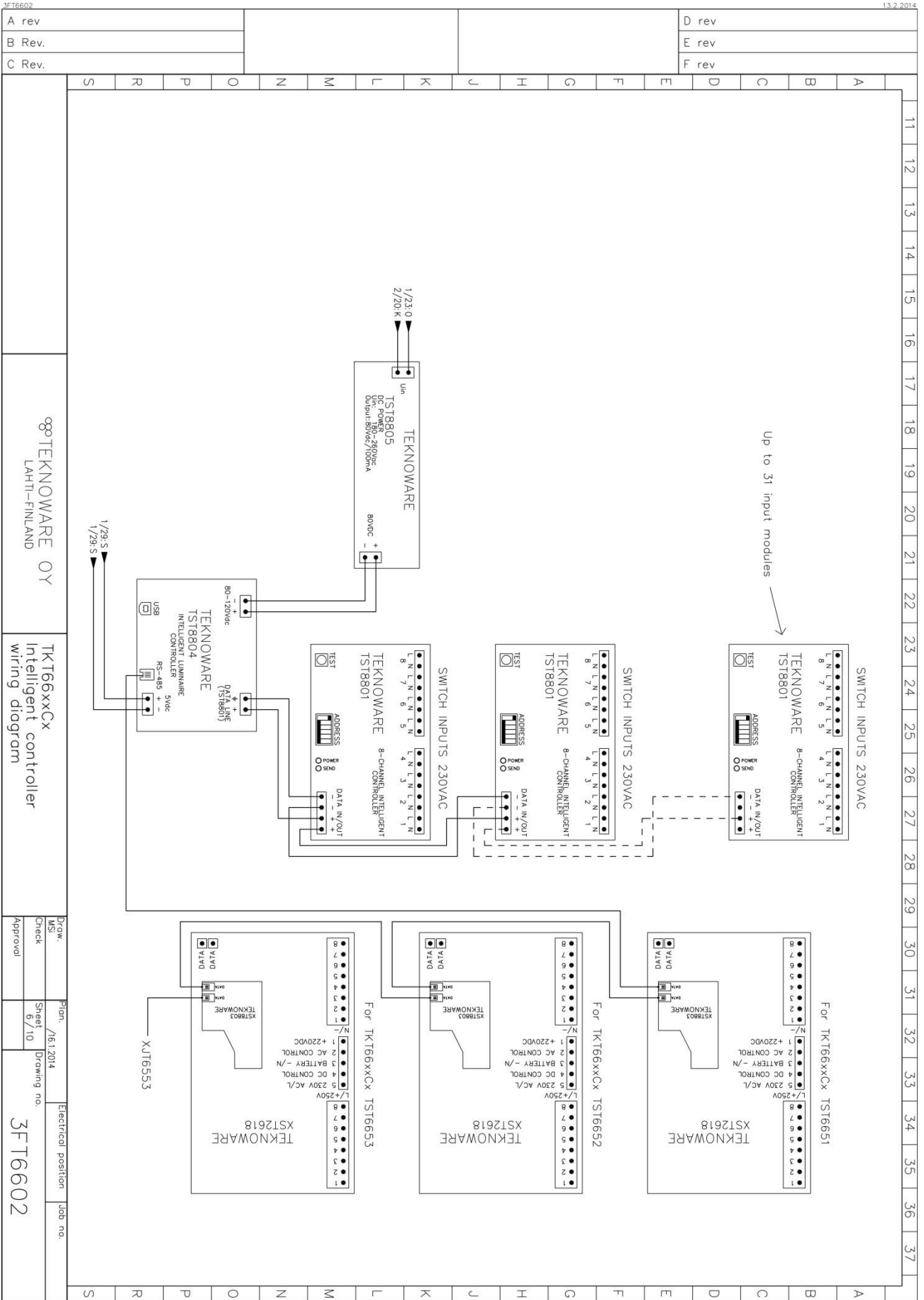

3FT6602

13.2.2014

A rev	D rev
B Rev.	E rev
C Rev.	F rev

TEKNOWARE OY
LAHTI-FINLAND

TK166xxxCx
Intelligent controller
wiring diagram

Draw. MSJ	Plan. /16.12014	Electrical position	Job no.
Check	Sheet 6/10	Drawing no.	
Approval		3FT6602	

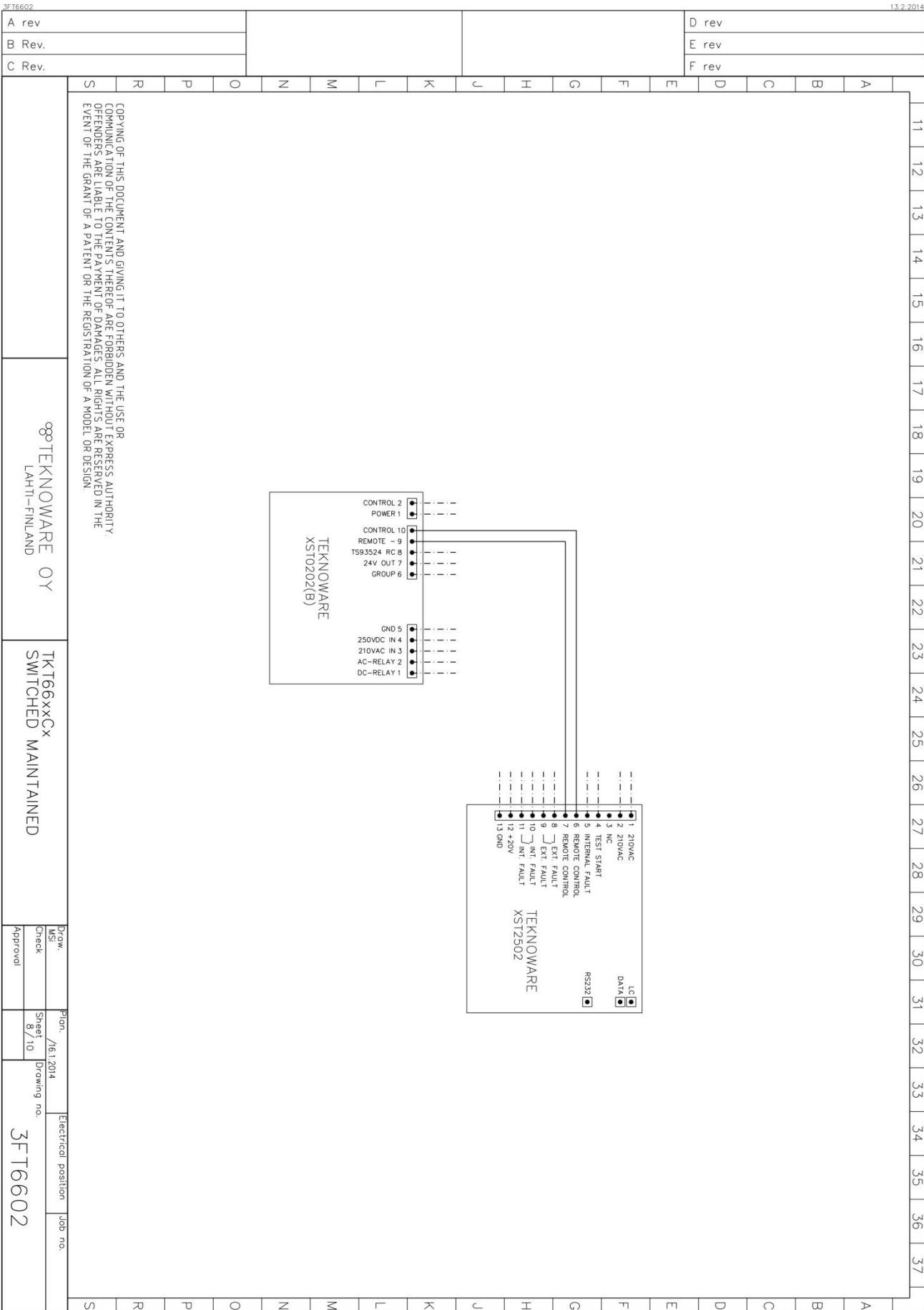

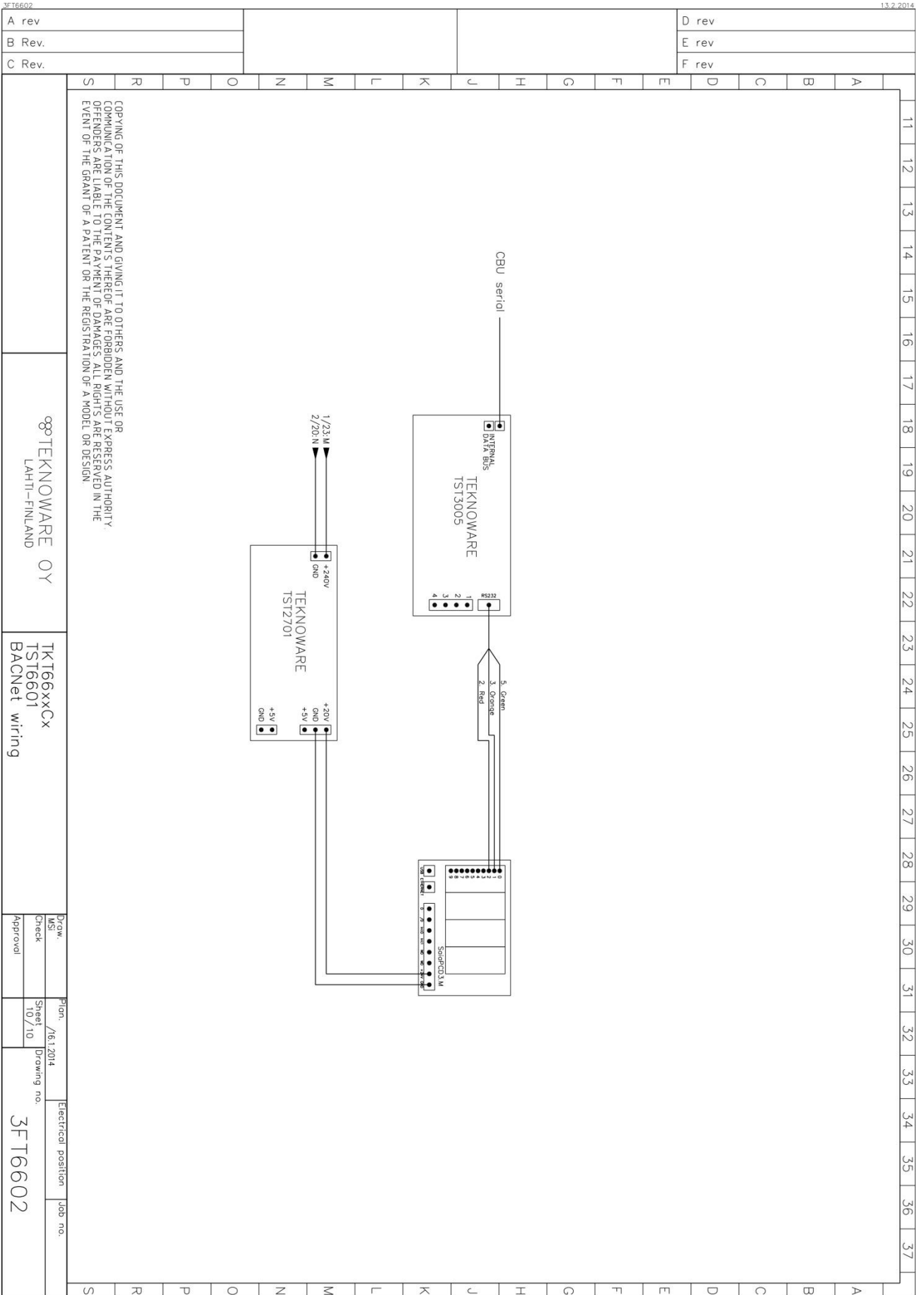

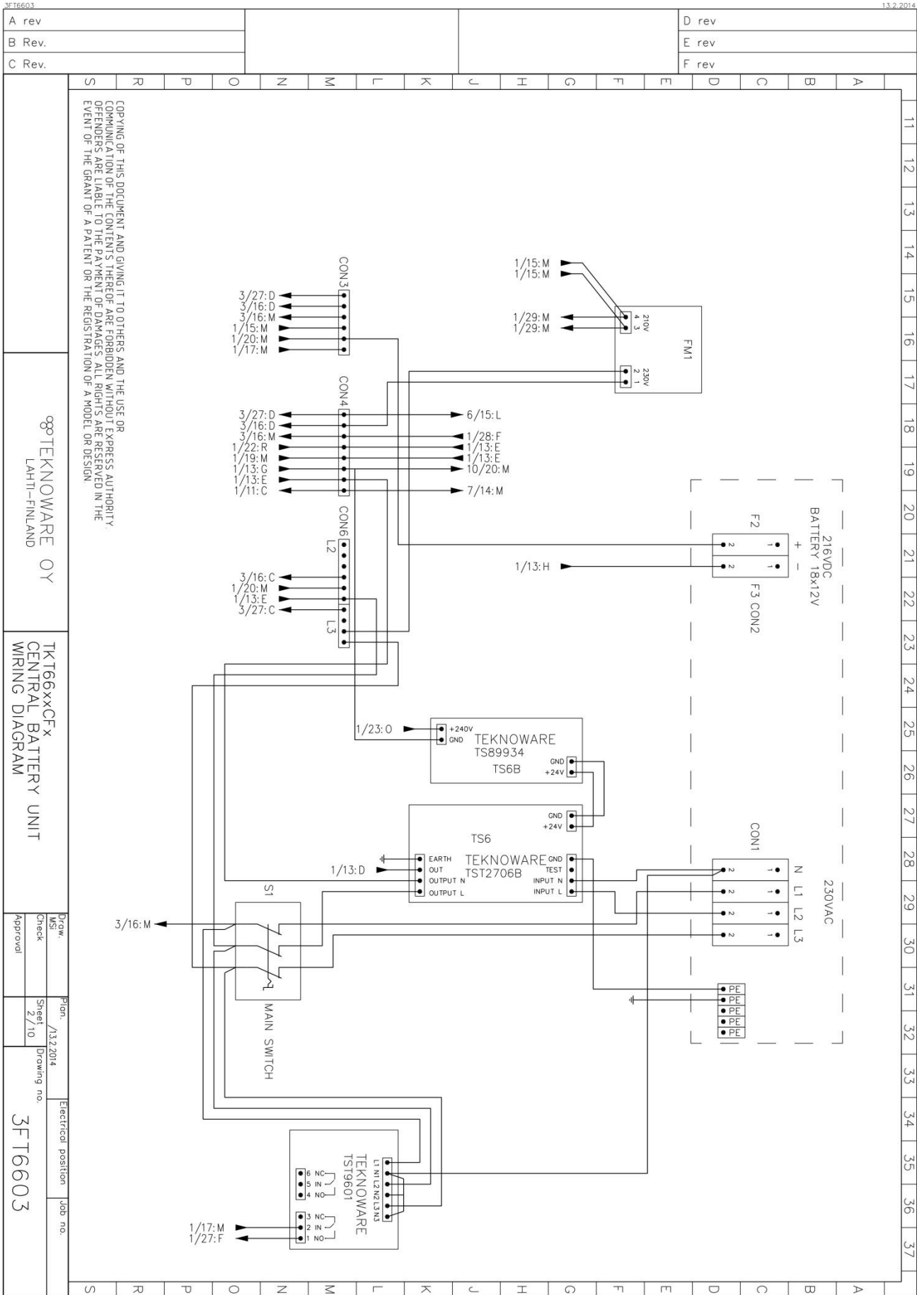

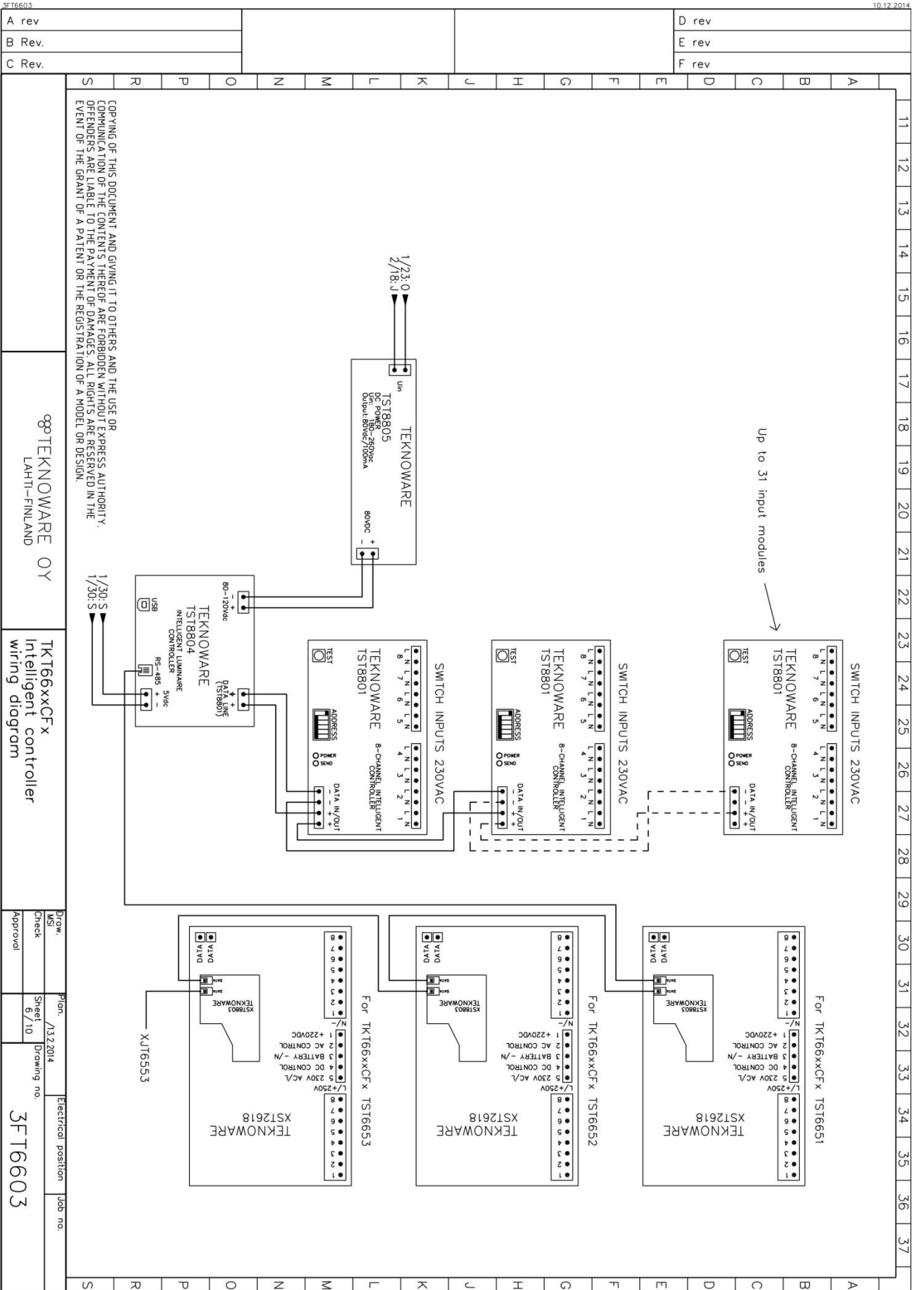

COPYING OF THIS DOCUMENT AND GIVING IT TO OTHERS AND THE USE OR COMMUNICATION OF THE CONTENTS THEREOF ARE FORBIDDEN WITHOUT EXPRESS AUTHORITY. OFFENDERS ARE LIABLE TO THE PAYMENT OF DAMAGES. ALL RIGHTS ARE RESERVED IN THE EVENT OF THE GRANT OF A PATENT OR THE REGISTRATION OF A MODEL OR DESIGN.

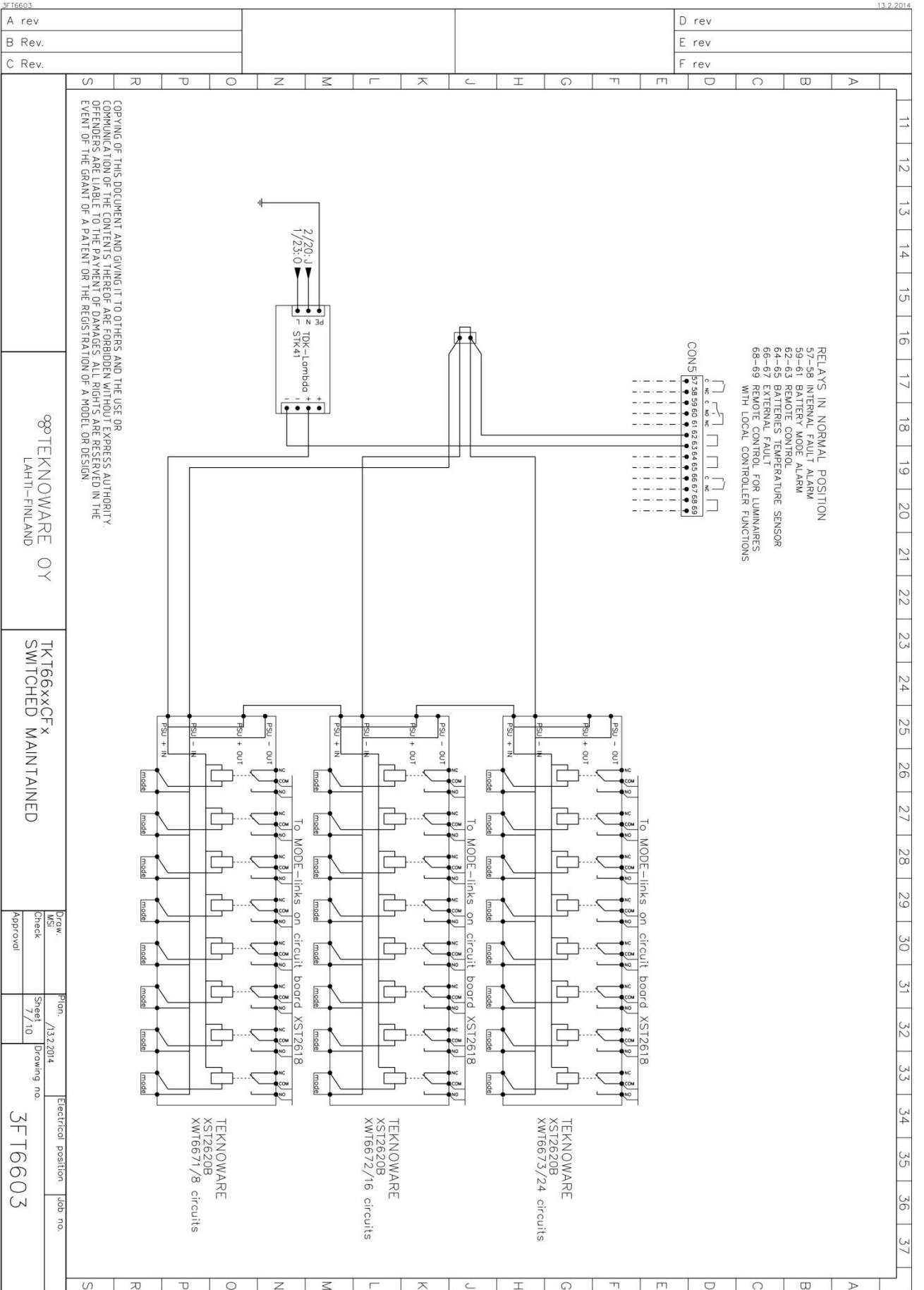

COPYING OF THIS DOCUMENT AND GIVING IT TO OTHERS AND THE USE OR COMMUNICATION OF THE CONTENTS THEREOF ARE FORBIDDEN WITHOUT EXPRESS AUTHORITY. OFFENDERS ARE LIABLE TO THE PAYMENT OF DAMAGES. ALL RIGHTS ARE RESERVED IN THE EVENT OF THE GRANT OF A PATENT OR THE REGISTRATION OF A MODEL OR DESIGN.

Drawn	MSI	Proj.	13.2.2014	Electrical position	Job no.
Check		Sheet	7/10	Drawing no.	3FT6603
Approval					

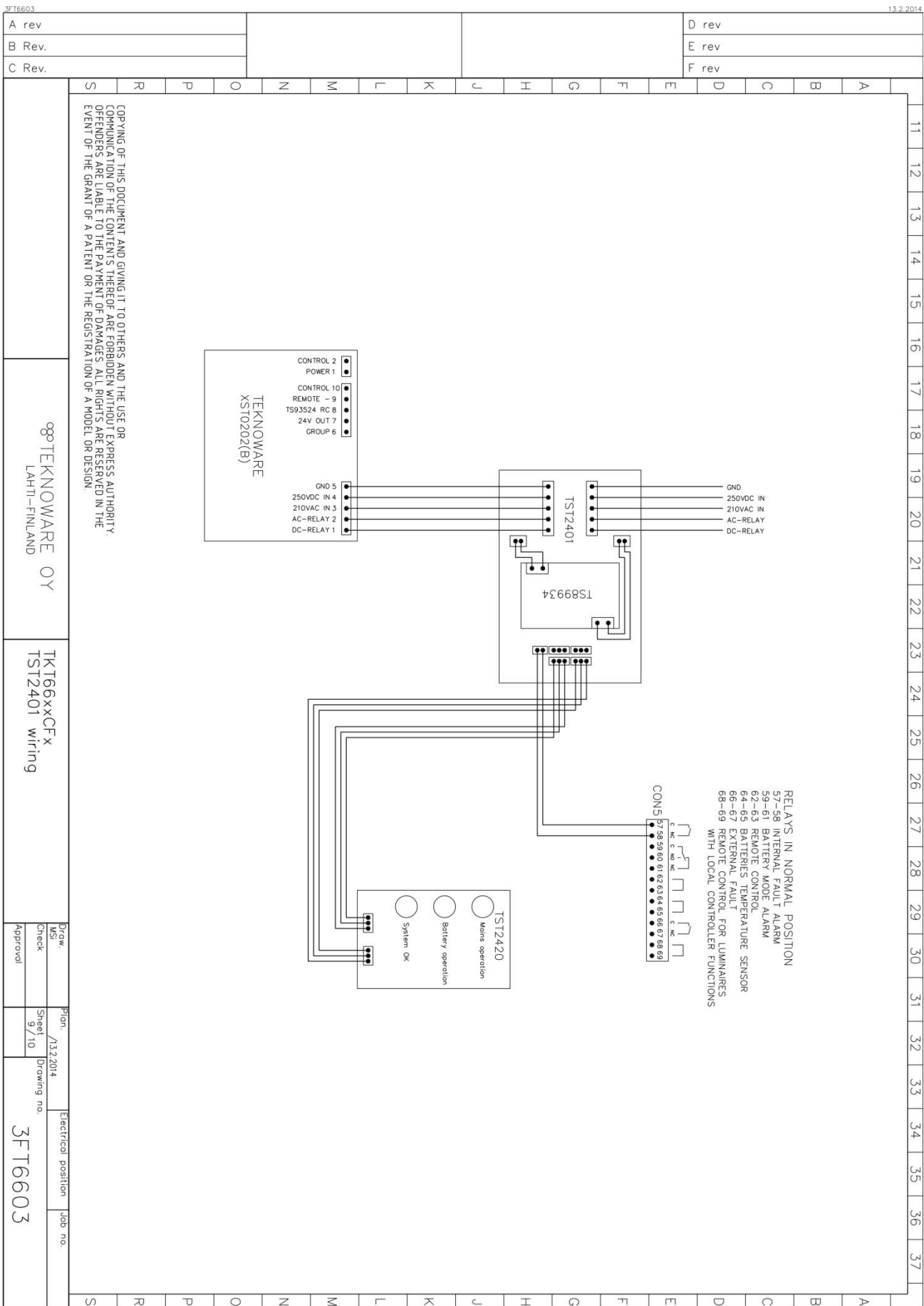

APPENDIX 7: Central battery unit main diagram, 3-phase

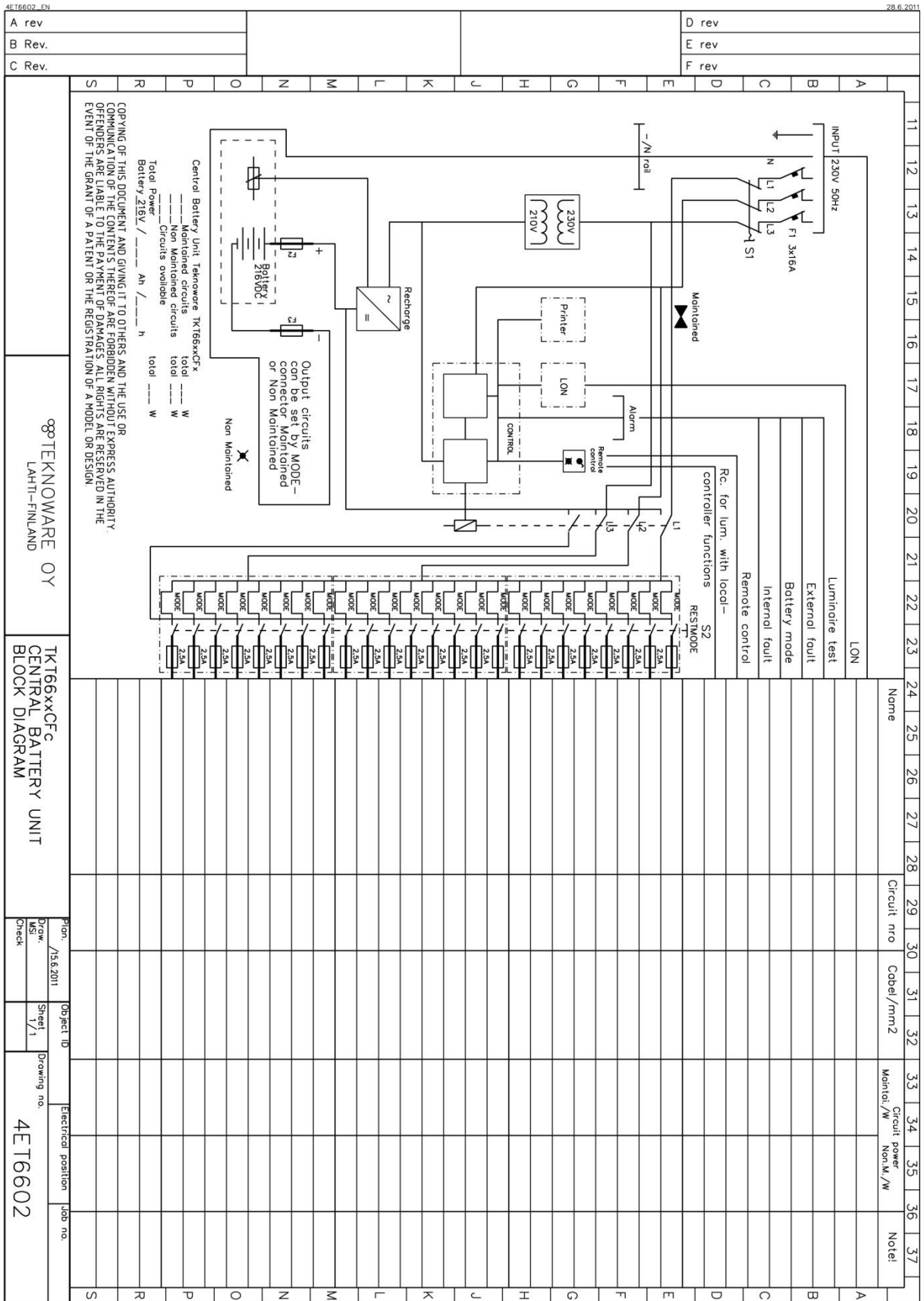

TEKNOWARE OY
LAHTI-FINLAND

TK166xxCFC
CENTRAL BATTERY UNIT
BLOCK DIAGRAM

Plan /15.6.2011
Drawn: MSL
Check

Object ID
Sheet 1

Drawing no.
4ET6602

Electrical position
Job no.

A rev	D rev
B Rev.	F rev
C Rev.	F rev

Name	Circuit nro	Cabel/mm ²	Montal./W	Circuit power NOM./W	Note!
LON					
Luminaire test					
External fault					
Battery mode					
Internal fault					
Remote control					
Rc. for lum. with local- controller functions RESTIMODE					
Printer					
Alarm					
Remote control					
Recharge					
Battery					
Output circuits MODE- connector Maintained or Non Maintained					
Non Maintained					
Monitored circuits					
Non Monitored circuits					
Circuits available					
Total Power					

